

Example part numbers and configurations

Part number	Position in chassis	Number of channels	Load protection rating
458M1/4S10	Position A	4	10 A
458M2/8S06 8S06	Position A	8	6 A
	Position B	8	6 A
458M3/8S06 8S06 8S10	Position A	8	6 A
	Position B	8	6 A
	Position C	8	10 A

1. Remove Cover, Knockouts (and Blanking Plates)

WARNING: THE BLANKING PLATE(S) PREVENT(S) ACCESS TO MAINS WIRING WHEN THERE IS NO MODULE CONNECTED.
DO NOT REMOVE THE BLANKING PLATE(S) UNLESS YOU ARE ATTACHING A MODULE.

Procedure

1. Open the door and remove the screws (**A** and **B**) from the inside door.
2. Remove the screws that are located to the left of the door (**C** and **D**)

Note:

- 458M1: 2 screws (**C** and **D**)
- 458M2: 3 screws
- 458M3: 4 screws

3. Remove the cover from the chassis.

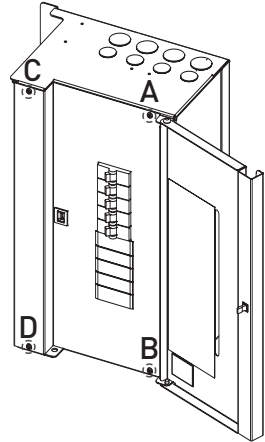

4. Remove knockouts as required.

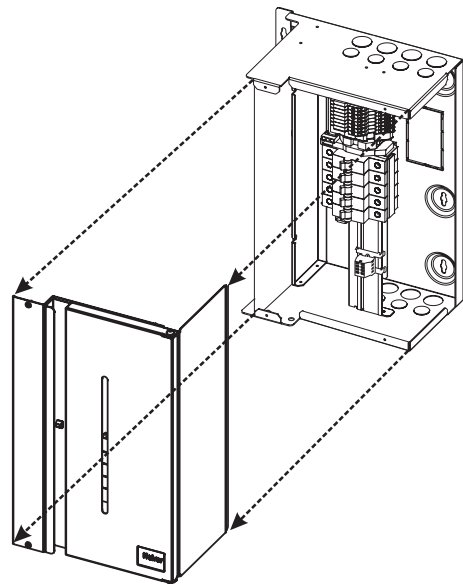

5. If you are attaching a module, unscrew and remove the blanking plate(s).

Note:

- 458M1: 1 blanking plate
- 458M2: 2 blanking plates
- 458M3: 3 blanking plates

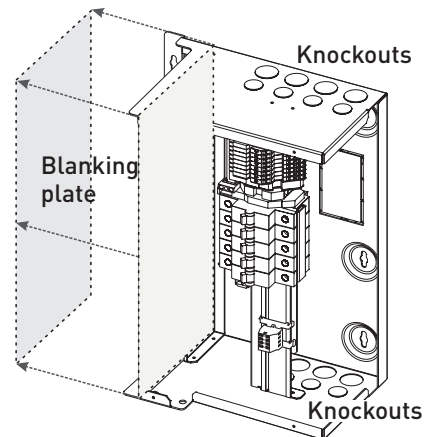

With the blanking plate(s) removed, the chassis is ready for a module to be attached (see diagram on page 3).

Note 1: The diagrams on this page show the 458M1/4S10 Chassis.
Covers and knockouts are removed from the 458M2 and 458M3 in a similar way.

Note 2: Use the grommets provided to protect cabling entering the knockouts.
If necessary, the knockout gland plates (on 458M2 and 458M3 types) can be removed to provide more space for cabling.

2. Mount to Wall

Mounting, Environmental and Clearance Requirements

Mounting

- Mount the chassis vertically on a flat surface.
- Use No. 8 or No. 10 screws with a head diameter between 6 mm and 9 mm.
- Use wall plugs if necessary.
- Mount chassis on wall using:
 - 4 screws for the 458M1 and 458M2 chassis
 - 6 screws for the 458M3 chassis

Environment

- The ambient temperature must be between 0 °C and +40 °C.
- Air humidity must be between 0 % and 90 % (noncondensing).
- The area must be adequately ventilated.
- Do NOT install this product in a damp location.

Clearance

- Make sure that enough space is left for ventilation and for attaching module(s): at least 5 cm above, below and to the right of the chassis, and 10 cm to the left. See 'Mounting Dimensions and Clearance' on page 4.
- Leave sufficient clearance to allow cables and trunking to be connected.
- When a Helvar module (e.g. a dimmer unit) is attached, the grilles must NOT be obstructed.

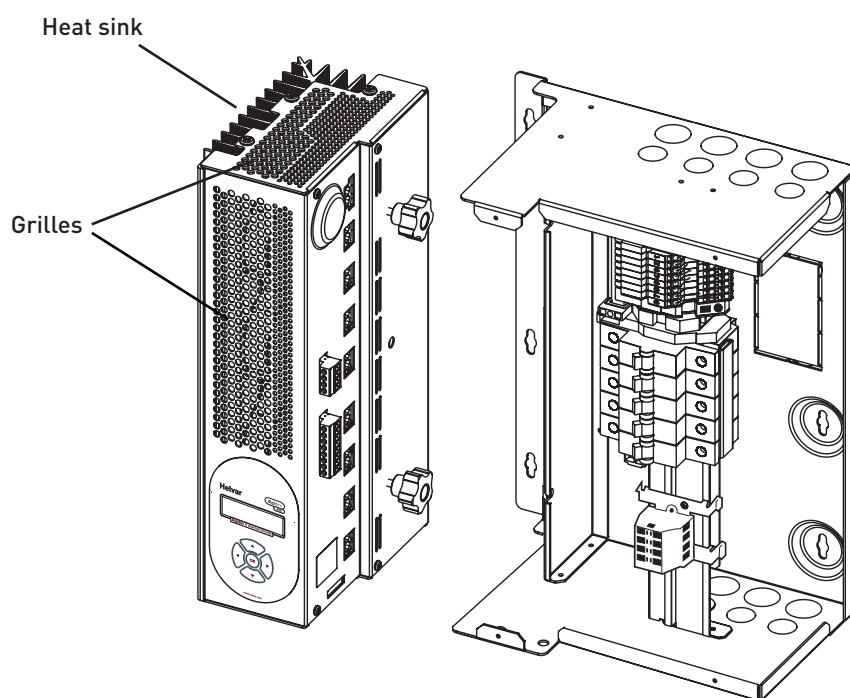

Module grilles and heat sink

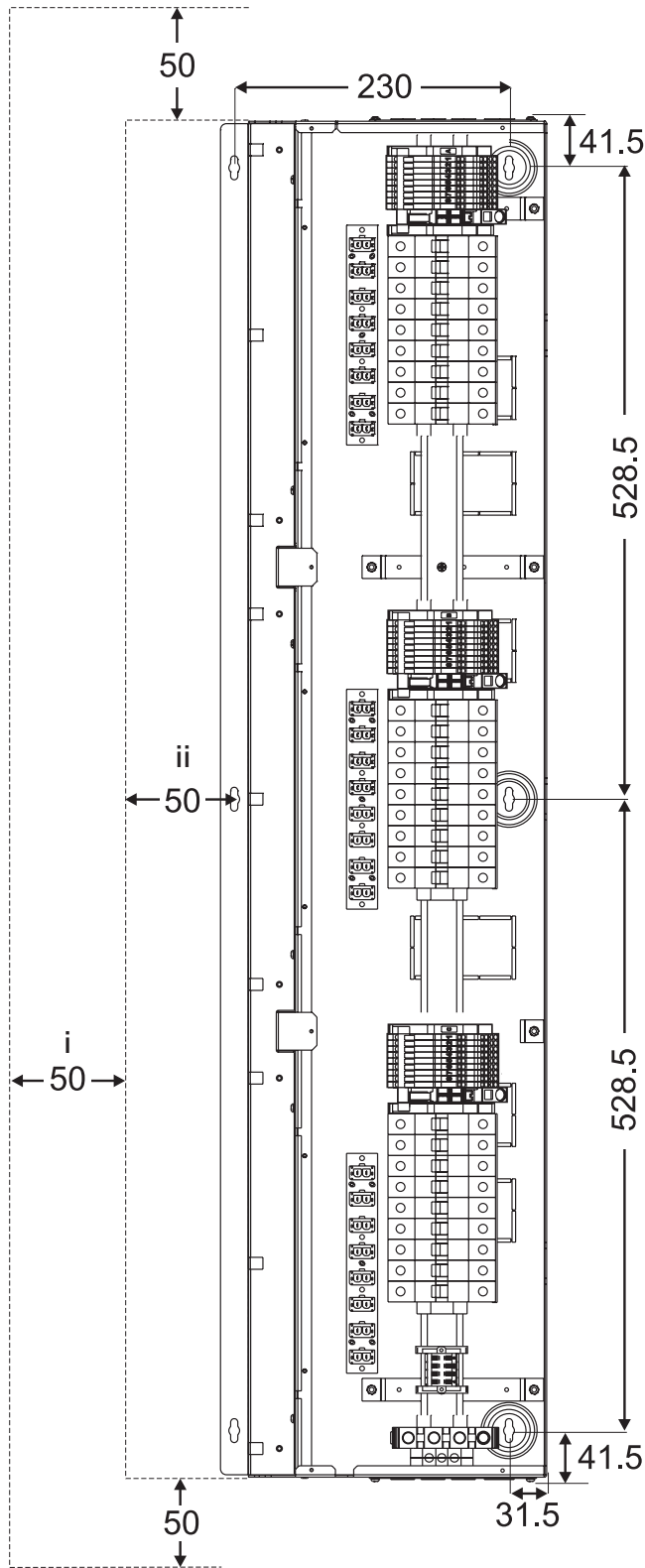

i = Clearance for ventilation
 ii = Clearance for modules

Chassis Mounting Hole Dimensions (mm)

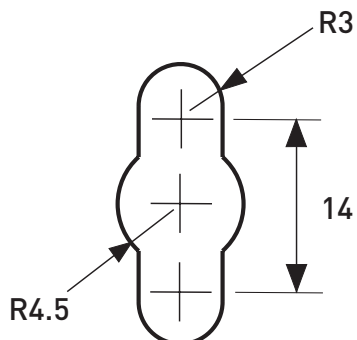

3. Electrical Installation

WARNING: *BEFORE STARTING ANY ELECTRICAL WORK, ISOLATE THE ELECTRICITY SUPPLY AT THE MAIN DISTRIBUTION BOARD.*

Cable Sizes and Strip Lengths

See 'Cable Requirements' on page 11 for cable sizes and required strip lengths.

Mains Supply Protection

The mains supply must be externally protected by a MCB or fuse not exceeding 17 kA. The incoming protection level must not exceed 63 A for each position. Single phase operation is limited to 125 A maximum by the neutral terminal block rating.

WARNING: *THE SUPPLY INPUT EARTH MUST BE CONNECTED.*

Using Spring-Lever Cage Clamp Terminals

Note: The supply earth, supply neutral and output terminals are spring-lever cage clamp terminals.

1. Insert a screwdriver as far as it will go into the terminal release point.
2. Lever the screwdriver back. This opens the cage clamp.
(For output terminals, levering the screwdriver back is unnecessary).
3. With the cage clamp open, do one of the following, as appropriate:
 - Insert the cable into the terminal.
 - Remove the cable from the terminal.
4. Release the pressure on the screwdriver, and then remove it. This closes the cage clamp.
5. If you have inserted a cable, make sure that the connection is secure.

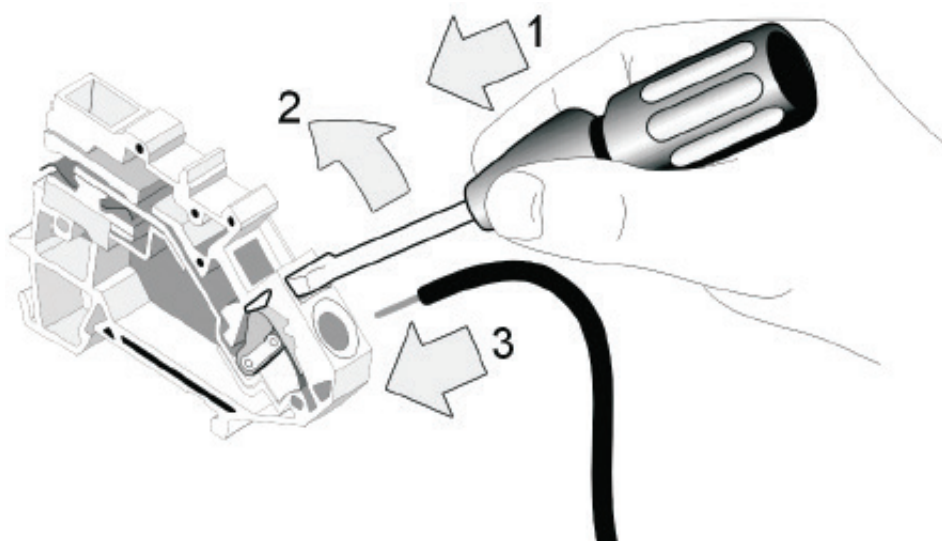

3.1 Connect SDIM Cable Loom to Modules (If Applicable)

If you are not wiring a 458M chassis to a Helvar module via SDIM, go to section 3.2, 'Connect Loads' on page 8.

An SDIM cable loom is attached to the DIN-rail inside the chassis (see 'Wiring Diagrams' on page 9).

This can be connected to the SDIM terminals of the module(s) to enable connection of the module(s) to a Helvar Imagine system (see diagrams below). The eight-terminal connector block is included with the 458Mx, wired to the cable loom.

SDIM Termination

If a unit is at the end of the SDIM cable line, you must link between terminals 'TERM' and 'B' for termination.

Note: The SDIM cable line needs two terminations: one at the beginning, and one at the end.

The following figure shows how to connect a 458M3 chassis to three modules:

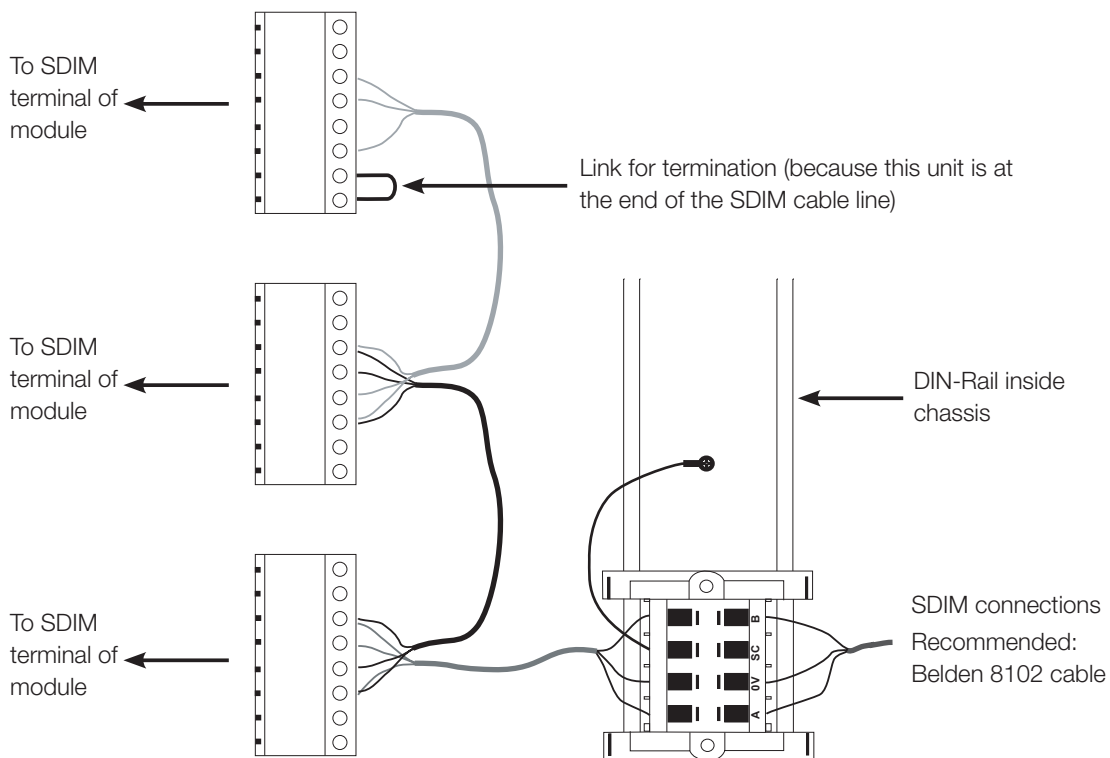

3.2 Connect Loads

Connect the loads to the output terminals as shown in the following figure (see separate 'Wiring Diagrams' for 458M1, 458M2 and 458M3 on page 9).

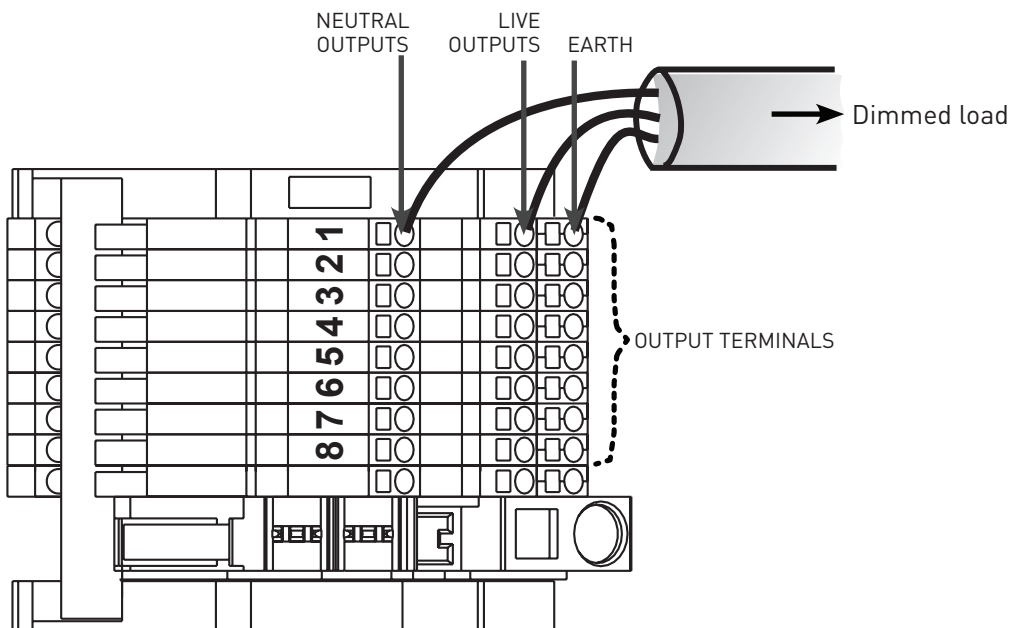

3.3 Connect Mains Supply

Connect the mains supply to the appropriate terminals (see separate 'Wiring Diagrams' for 458M1, 458M2 and 458M3 on page 9):

1. Connect live to the appropriate MCB block(s):
 - In the 458M1, connect L.
 - In the 458M2, connect L1 and L2.
 - In the 458M3, connect L1, L2, and L3
2. Connect neutral (N) to the neutral terminal block.

In the 458M1, the neutral terminal block is located between the output terminal block and the MCB block.

In the 458M2 and in the 458M3, the neutral terminal block is located at base of the unit, under the SDIM cable loom.
3. Connect earth (E) to the earth terminal block.

Note 1: The bypass terminals allow you to operate and test the lights and the installation wiring without (a) module(s) connected to the chassis.

Note 2: Always dock unused dimmer feeds in bypass connectors.

Note 3: Make sure that the MCB terminals are clearly identified for load circuit connection.

Wiring Diagrams

458M1

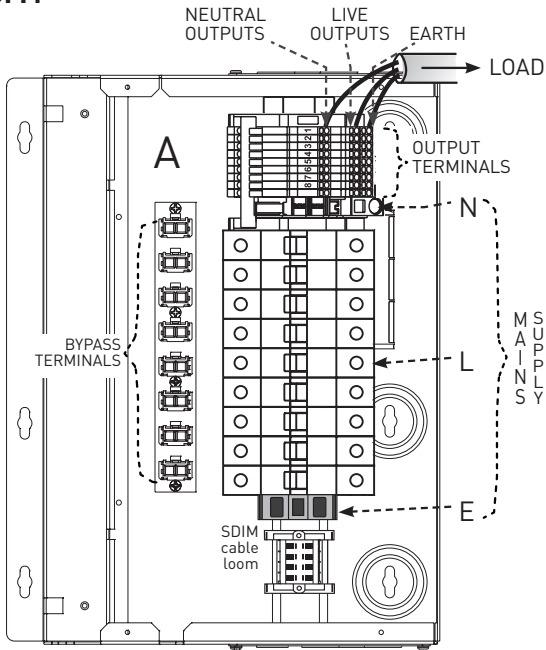

458M3

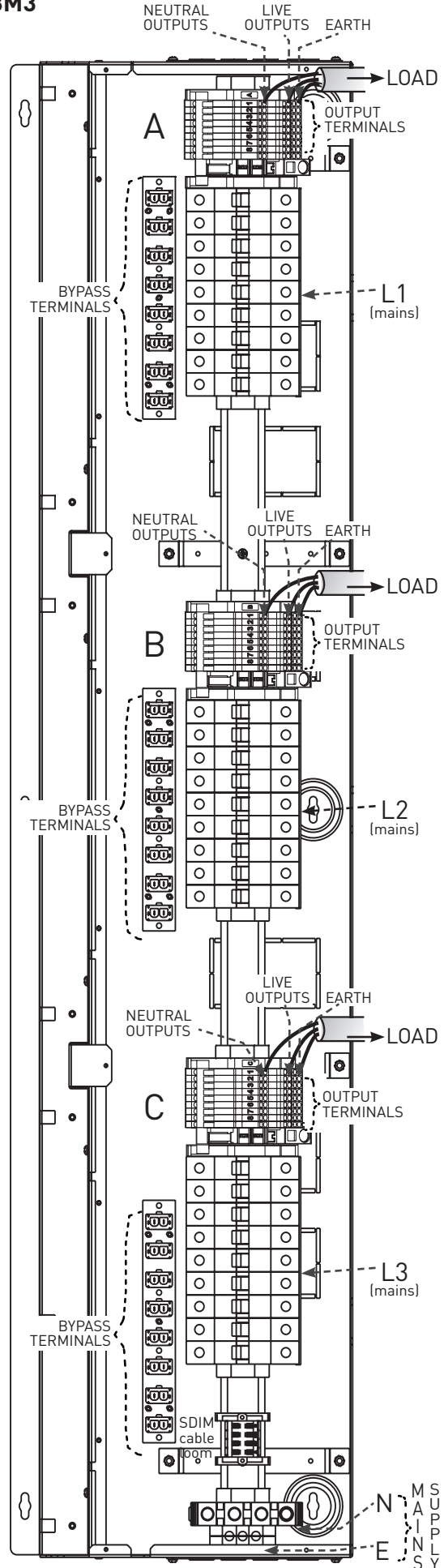

458M2

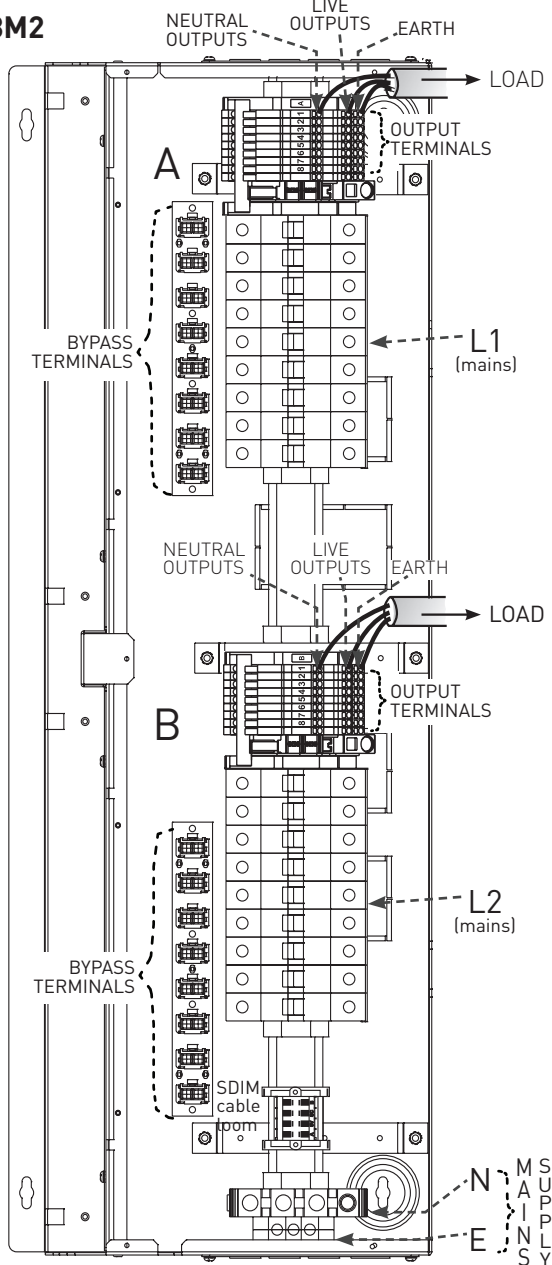

Dimensions: Case (mm)



freedom in lighting

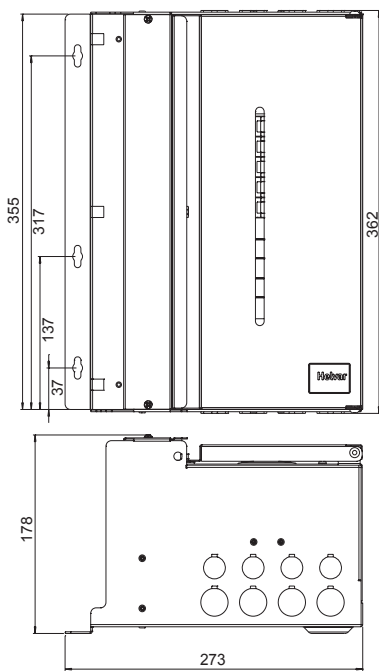

458M1

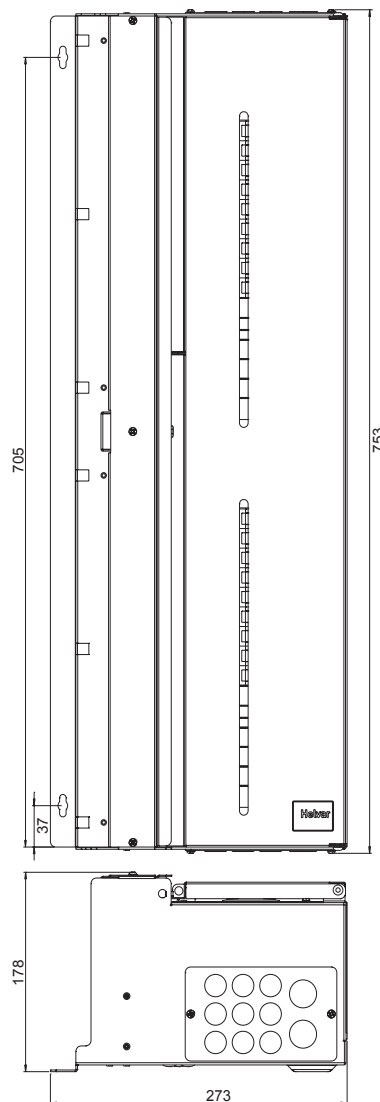

458M2

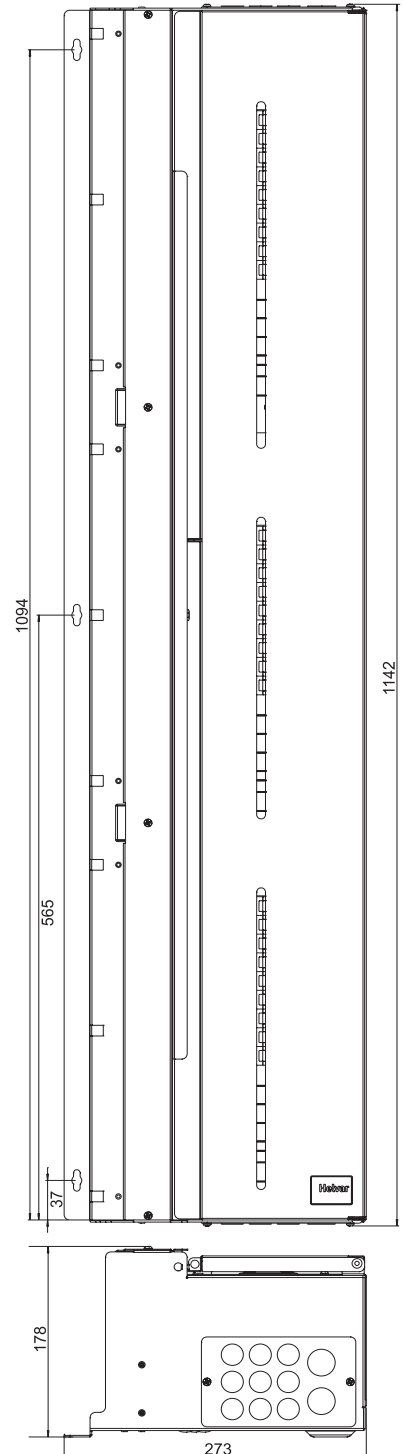

458M3

Connections

Mains supply:	230 VAC / 400 VAC
Supply protection:	External MCB or fuse 458M1, 458M2, 458M3: 63 A (max.) for each position Single phase use: 125 A (max.) <i>Note: Supplying multiple blocks of MCBs on the same phase requires this limit because of the neutral connection.</i> Rated \leq 17 kA to meet EN 61439-2
Load protection:	MCB type C 10 kA. Rating as specified for individual units.
SDIM cable loom:	An SDIM cable loom is attached to the DIN-rail inside the chassis. This can be connected to the SDIM terminals of the module(s), to enable connection of the module(s) to a Helvar Imagine system.

Installation

Mounting:	Vertically wall mounted: 4.5 mm mounting holes. Use No. 8 or No. 10 screws with head diameter of 6 mm to 9 mm.
------------------	---

Mechanical Data

Dimensions:	See diagrams.
Weight:	
458M1:	5.9 kg (458M1 including 9 MCBs)
458M2:	12.2 kg (458M2 including 18 MCBs)
458M3:	18 kg (458M3 including 27 MCBs)

Operating Conditions

Ambient temperature:	0 °C to +40 °C
Relative humidity:	Max. 90 %, noncondensing
Storage temperature:	-10 °C to +70 °C

Conformity and Standards

Safety:	EN 61439-2
Environment:	Complies with WEEE and RoHS directives

Cable Requirements

Connection	Cable type (Cu)	Strip length
Mains supply: 458M1	Up to 16 mm ²	16 mm – 17 mm (N); 12-13 (E)
Mains supply: 458M2	6 mm ² – 35 mm ²	12 mm – 14 mm (N), 17 (E)
Mains supply: 458M3	6 mm ² – 35 mm ²	12 mm – 14 mm (N), 17 (E)
Channel outputs:	Solid core: 0.25 mm ² – 4 mm ² ; Stranded: 0.25 mm ² to 2.5 mm ²	10 mm – 12 mm
SDIM / DMX	Low-loss 300 V RS485 type; Multistranded, twisted and shielded; 3- or 4-core plus screen; 0.22 mm ² – 1.5 mm ² Recommended: two twisted pairs (overall screened), e.g. Belden 8102 CM.	Max. length: 1000 m