

458/CTR8 8-Channel Ballast Controller Module

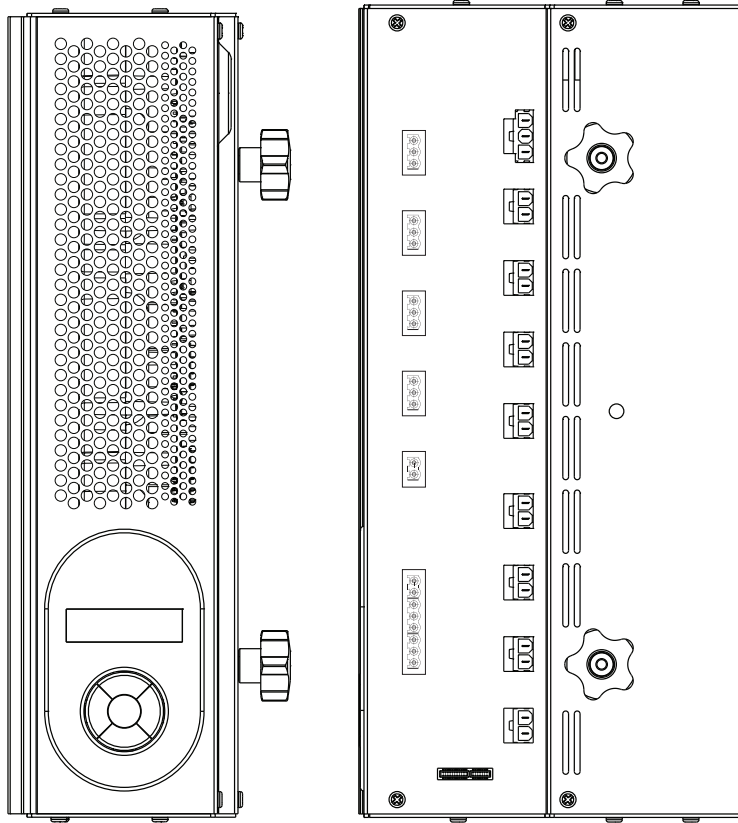

Contents

<u>Section</u>	<u>Page</u>
Introduction	1
Installation	2
1. Attach the module to a chassis	2
2. Connect power and load cables to module sockets	3
3. Make control connections	4
4. Replace the chassis cover	4
5. Power on the unit	4
Load types	5
Control Panel	5
Control Panel functions	5
Control Panel LCD Display	6
Control Panel Keypad	6
Adjusting channel and output levels with the Control Panel Keypad	7
Navigating the menu with the Control Panel Keypad	7
Physical selection	8
Menu options	9
Main menu	9
Menu options details	10
Error messages	15
Dimensions (mm)	15
Technical specifications	16

Introduction

The 458/CTR8 is an eight-channel digital ballast controller module capable of controlling 0–10 V, 1–10 V, DSI®, DALI broadcast or PWM loads. It has both a DALI and an SDIM/DMX interface, and therefore can be fully integrated into a DIGIDIM or an Imagine router system. It can also be used on the TouchPanel or on standalone DALI or DIGIDIM systems.

Note: DALI and SDIM/DMX must not be connected simultaneously.

Chassis modules

The 458/CTR8 module is attached to the 458M1, 458M2 or 458M3 chassis. The chassis modules are supplied with control module by-pass connectors, and can be fully installed and wired prior to fitting of the control module(s). Thus, all electrical installation, testing and powering up of the lighting circuits can be carried out prior to the fitting of the control modules, which prevents possible damage to the control modules due to circuit overload or faults or to the use of high-voltage insulation testing equipment.

LCD display and keypad

The front of the module is equipped with an LCD display and keypad to set basic configuration parameters and provide basic control of channel and output levels. For information, see 'Control Panel' on page 5.

Channels and load protection

The module has eight high-inrush relays, rated at 16 A per channel.

Note: The correct chassis load protection must be chosen to ensure that the required channel ratings are achieved, but not exceeded.

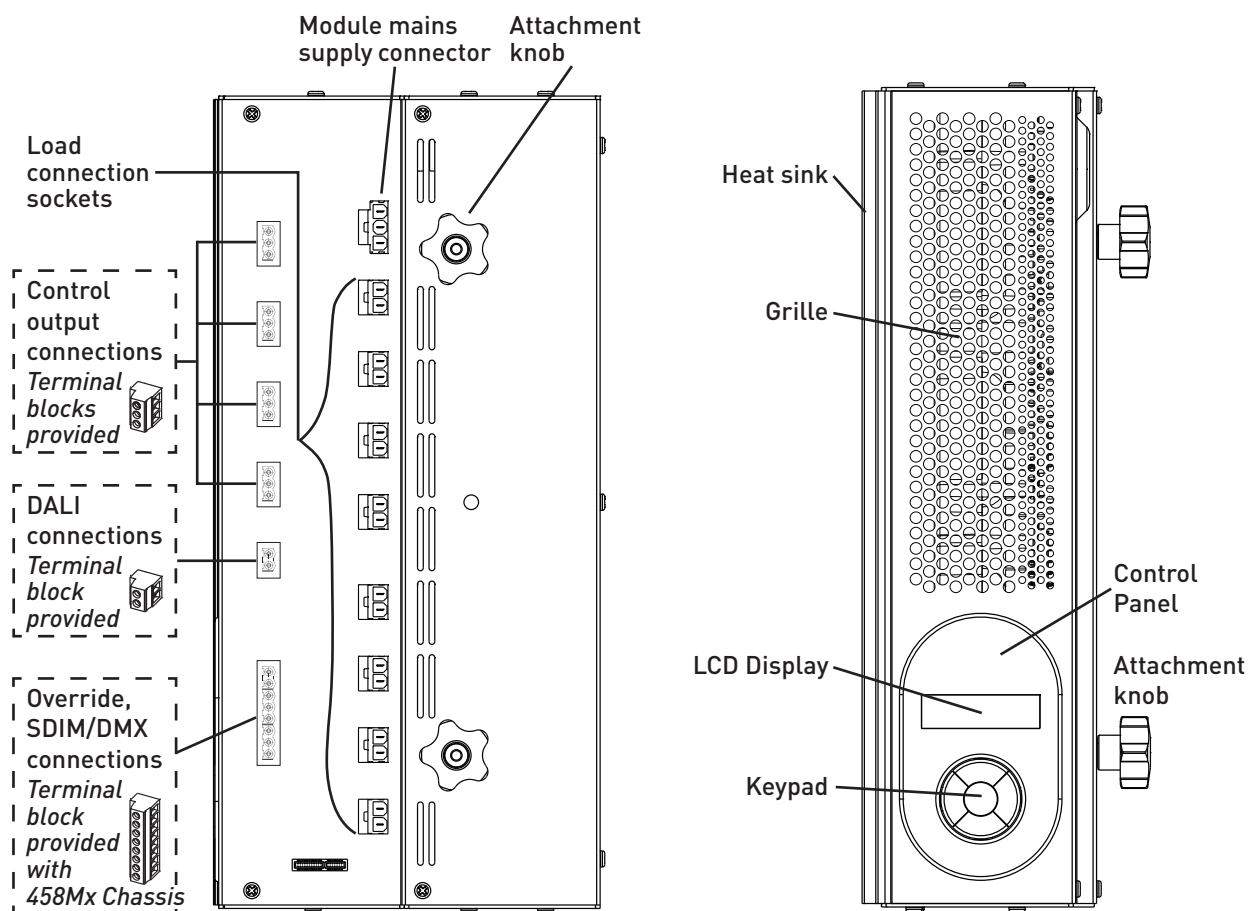

DSI® is a registered trademark of Tridonic GmbH.

Installation

1. Attach the module to a chassis

Mounting, environmental and clearance requirements

Mounting

- Attach the 458/CTR8 to a 458M1, 458M2, or 458M3 chassis that is mounted vertically on a flat surface.

Environment

- The ambient temperature must be between 0 °C and +40 °C.
- Air humidity must be between 0 % and 90 % (noncondensing).
- The area must be adequately ventilated.
- Do NOT install this product in a damp location.

Clearance

- For effective ventilation, ensure that there is adequate space around the combined chassis and module(s): 50 mm above, below and on both sides. Refer to the mounting dimensions and clearance diagrams in the 458Mx Chassis Installation Guide.
- When a Helvar control module (e.g. 458/CTR8) is attached, the grilles must NOT be obstructed.

For further information, refer to the Helvar 458Mx Chassis Installation Guide.

Warning: Before attaching the module and making any connections, make sure that the mains supply is isolated.

Important: The module may be controlled by either DALI or SDIM/DMX, but DALI and SDIM/DMX must not be connected simultaneously.

1.1 Remove chassis cover

For details, refer to the 458Mx Chassis Installation Guide.

1.2 Remove chassis blanking plates

Unscrew and remove the blanking plate(s) from the chassis.

- Note 1:** 458M1: 1 blanking plate
 458M2: 2 blanking plates
 458M3: 3 blanking plates

Note 2: The diagrams on this page show the 458M1/4S10 Chassis. Covers and knockouts are removed from the 458M2 and 458M3 in a similar way.

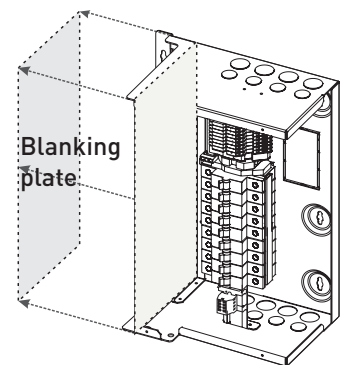

1.3 Loosen attachment knobs

Partially unscrew the two knobs on the module to reveal the pins.

1.4 Slot module pins into mounting bracket

Attach the module to the chassis by slotting the pins of the module to the mounting bracket.

1.5 Tighten knobs

Screw the knobs to the mounting bracket to secure the module.

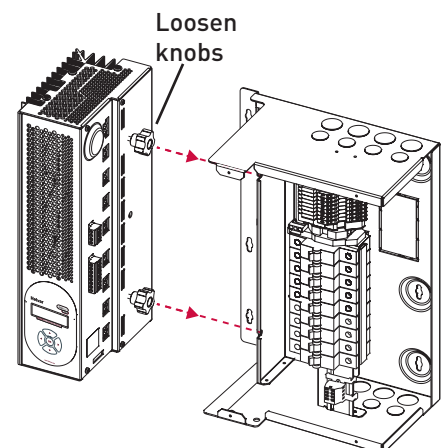

2. Connect power and load cables to module sockets

Connect the mains control supply as shown below. The load output cables from the 458M chassis will be plugged into the chassis bypass terminals. Unplug the cables, and then connect them to the module channel terminals.

Note: The diagram on this page shows the 458M1 chassis. Cable connection is similar for the 458M2 and 458M3.

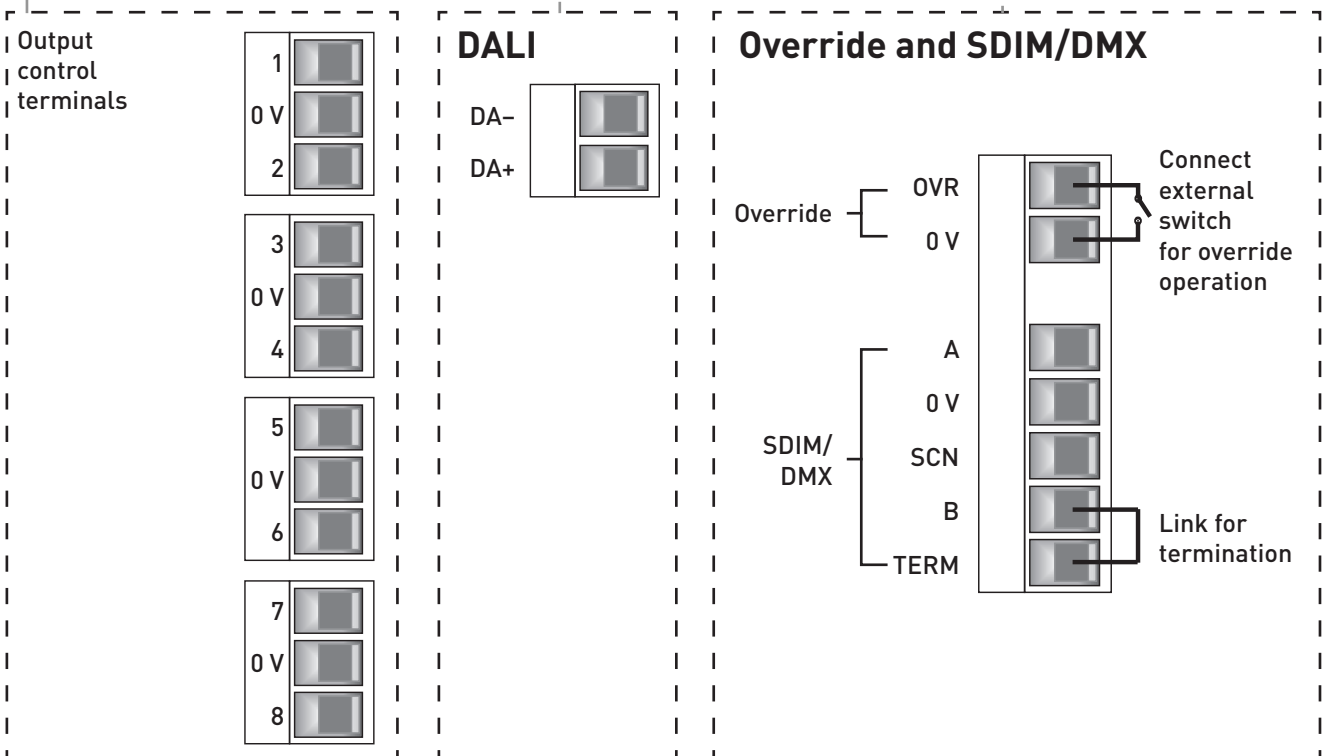
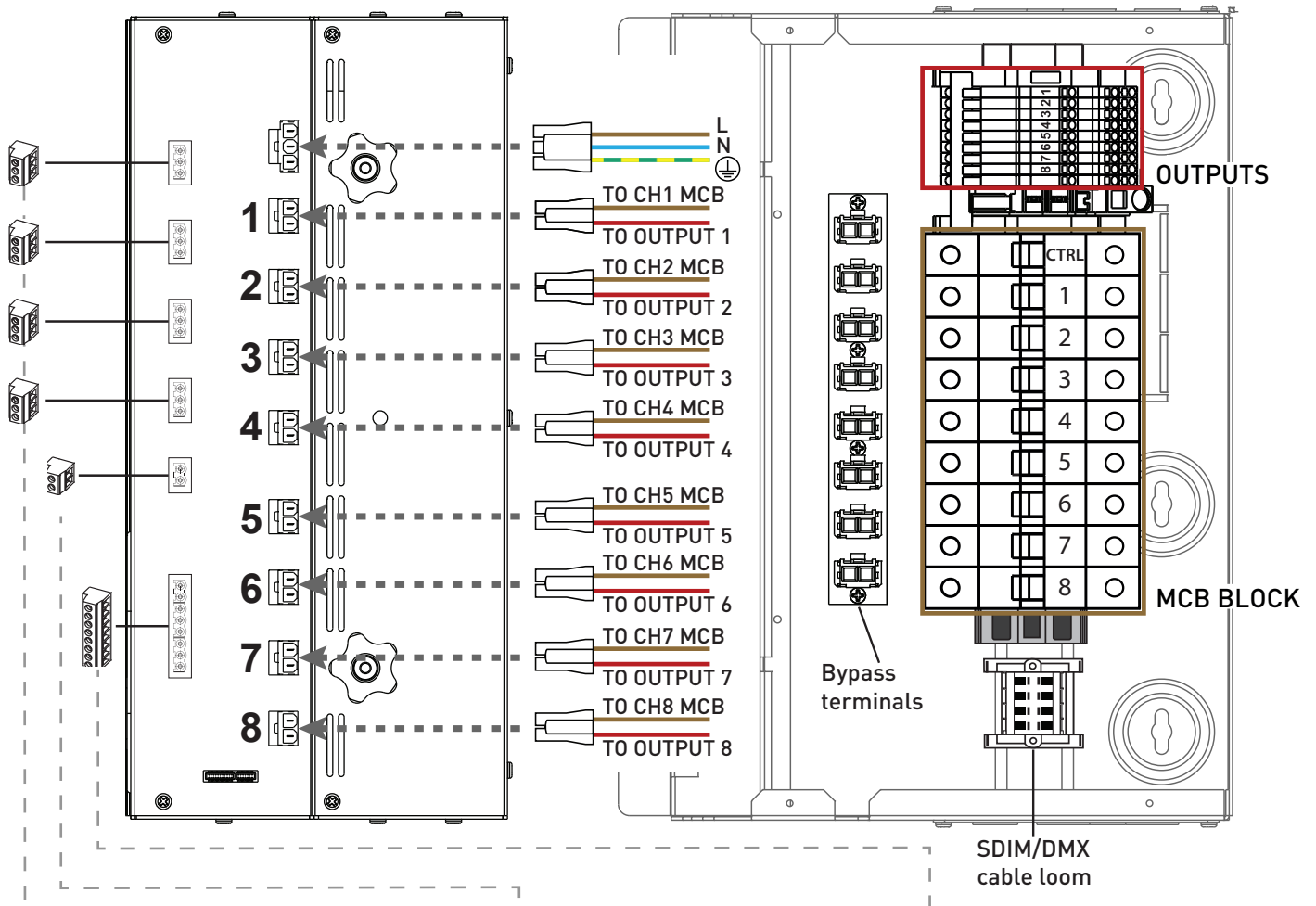

3. Make control connections

Refer to the connection diagrams on the previous page.

Ensure that all the necessary control connections have been made correctly and securely.

Warning: Ensure segregation between mains cabling and other connections.

DALI and 1–10 V ballast connections must be considered as potentially live.

3.1 DALI connections

If connecting to a DIGIDIM system, use the DA+ and DA– terminals of the DALI connector.

3.2 Override connections

If you want to provide output level override functionality, wire a switch between the '0 V' and 'OVR' terminals of the SDIM or DMX connector. Switch closure sets the light level of all output channels to the override level.

3.3 SDIM and DMX connections

If connecting to a Helvar Imagine system, plug in the connector of the SDIM/DMX cable loom to the SDIM/DMX terminals. This is attached to the DIN-rail inside the chassis.

If the module is at the end of the SDIM/DMX cable, wire a link between the 'TERM' and 'B' connections of the SDIM/DMX terminals to enable the cable termination.

3.4 Output control connections

Connect the required output control connections to the output control terminals of the module. The following diagram shows an example.

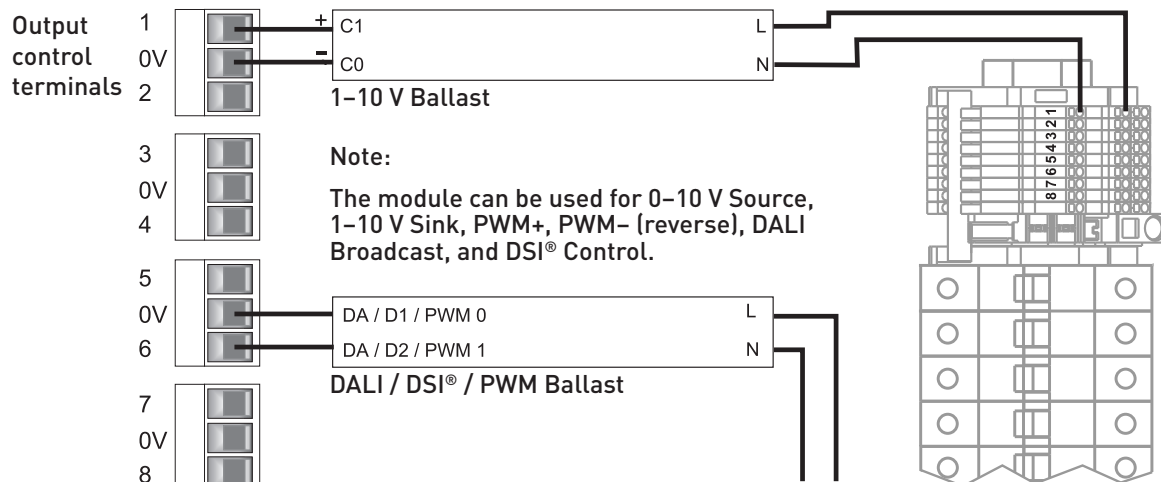

4. Replace the chassis cover

Replace the chassis cover, using the original screws.

5. Power on the unit

Power up the module by switching on the MCBs.

The Control Panel LCD Display will show the Main Display Screen. For details, see 'Main Display Screen' on page 6.

Load types

Each channel of the 458/CTR8 control module can be configured to operate in any of the following modes:

- 0–10 V → source 20 mA
- 1–10 V → sink 100 mA
- DSI® (Digital Signal Interface) → source 100 mA
- PWM (Pulse Width Modulation) → source 100 mA
- DALI broadcast → source 100 mA

Control Panel

Control Panel functions

The Control Panel is used to view and adjust:

- Relay and output channel levels
- Various relay and output parameters

SDIM connection

Example: to Helvar 920 Routers, or to Helvar TouchPanel.

Adjust the following parameters with the Control Panel:

- Channel pairing
- SDIM addresses

Other parameters can be set using Designer software.

DMX connection

Example: to Helvar 920 Routers, or to third party lighting desk.

Adjust the following parameters with the Control Panel:

- DMX addresses
- Channel pairing
- Output mode
- Minimum fade time
- Override level
- Switch-on level

Other parameters can be set using Designer software.

DALI connection

Example: to Helvar 920 Routers.

Adjust the following parameters with the Control Panel:

- Channel pairing
- Minimum fade time
- Override level

Other parameters can be set using Designer software.

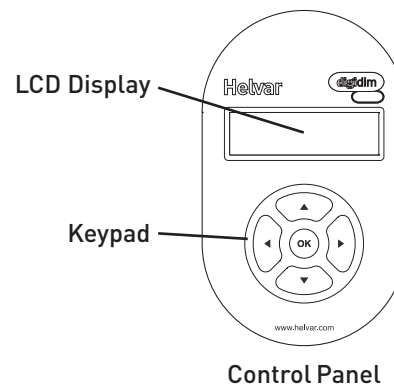

DALI standalone connection with Toolbox software

Adjust these parameters with the Control Panel:

- Channel pairing
- Minimum fade time
- Output mode
- Override level

Other parameters can be set using Toolbox software.

DALI standalone connection

This allows basic out-of-box scene recall, modify and store from DALI control panels. Other settings can be changed with the module Control Panel.

Note: *If SDIM or DMX is connected and you change lighting levels or recall scenes on the Control Panel, then, after a short period of time, the levels revert to those being sent by the SDIM/DMX master.*

Control Panel LCD Display

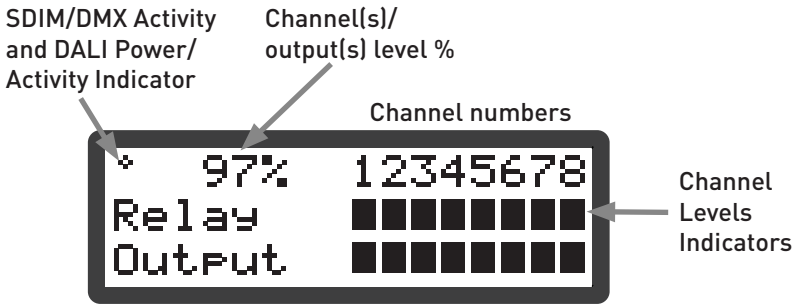

SDIM/DMX Activity and DALI Power/Activity indicator

This indicator in the top left-hand corner of the Control Panel LCD Display indicates SDIM/DMX activity or DALI power/activity:

- For SDIM/DMX it is normally off, and flashes on intermittently for activity.
- If DALI power is on, then the indicator is on. It flashes to indicate DALI activity.

Channel(s)/output(s) level %

The percentage shown is the level of the currently selected channel(s) or output(s).

'ALL' is displayed here if all channels or outputs are selected simultaneously but are set to different levels.

Main Display Screen

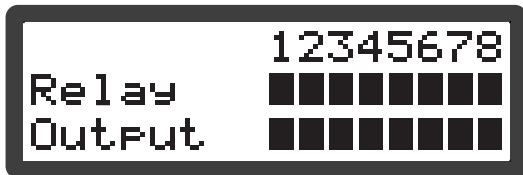

The Main Display Screen appears:

- When the 458/CTR8 is powered on.
- After 60 seconds of inactivity on the Control Panel.
- After exiting the Control Panel options.

Control Panel Keypad

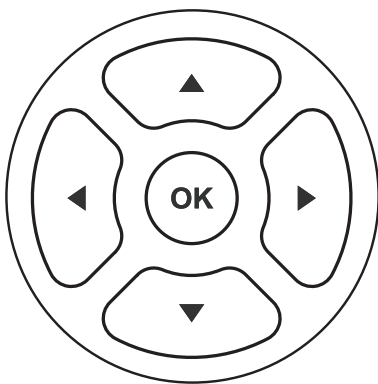



Use the Control Panel Keypad to:

- Set output channel levels.
- Navigate the system menus to adjust module settings.



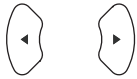
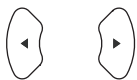



Adjusting channel and output levels with the Control Panel Keypad

Follow these steps to adjust channel and output levels.

<p>1.</p> 	<p>(From the Main Display Screen): Press either RIGHT or LEFT to access the relay and output (option) channel levels.</p>
<p>2.</p> 	<p>Step left or right through channels/outputs. The selected channel(s) or output(s) are shown by a flashing bar or 'o' (to indicate 0 % light level).</p>
<p>3.</p> 	<p>Adjust lighting level percentage (%) for the selected channel(s).</p>
<p>4.</p> 	<p>Return to the Main Display Screen.</p>

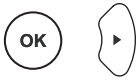
Navigating the menu with the Control Panel Keypad



Follow these steps to access and navigate the menus.

<p>1.</p> 	<p>(From the Main Display Screen): Press UP or DOWN to access the menu options.</p>
<p>2.</p> 	<p>Scroll through main options.</p>
<p>3.</p> 	<p>Select an option (access option screen).</p>
<p>4.</p> 	<p>Adjust parameters.</p>
<p>5.</p> 	<p>Step among different parameters in options screens.</p>
<p>6.</p> 	<p>Return to previous menu. Return to the Main Display Screen (from the main menu).</p>

Physical selection

Physical selection mode is activated using a Helvar remote control unit. It allows you to group loads and controls together without the use of programming software. For details, refer to the equipment instructions.

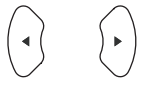
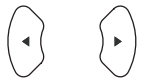
Follow these steps to identify a piece of equipment using physical selection mode.

1.	-	Put the piece of equipment (e.g. router, sensor, etc.) into 'physical selection mode' (refer to the manufacturer's instructions).
2.		(From the Main Display Screen): Press either RIGHT or LEFT to access the relay and output channel levels.
3.		Step left or right through channels to select the channel that you want to use for physical selection.
4.		Press UP or DOWN to physical select the channel.
5.	-	Repeat steps 3 and 4 for each channel, as necessary.
6.	-	Once identified, end 'Physical selection mode' for the piece(s) of equipment (refer to the manufacturer's instructions).

Menu options

Main menu

Use the Control Panel Keypad to access and navigate and to adjust the menu options – see ‘Navigating the menu with the Control Panel Keypad’ on page 7.

Below is a table listing the main options available from the Control Panel. Full options details are listed in the next section.

Addresses	Set SDIM, DMX and DALI addresses, including base addresses, and SDIM/DMX mode.
Ballast output	View and refresh ballast status; pair relay and ballast channels; set output mode.
Unit details	View module serial number, firmware version, and various other service-related information.
Recall scene	Recall DALI scenes.
Save as scene	Save levels as a DALI scene.
Default scenes	Reset DALI scenes to default settings.
Groups	Group and ungroup relay and ballast channels.
Min. fade time	Set minimum fade times for relay and ballast channels.
Power on level	Set DALI power-on levels for relay and ballast channels.
Failure level	Set (or disable) DALI failure levels for relay and ballast channels.
Override level	Set (or disable) override levels for relay and ballast channels.
Minimum level	Set DALI minimum load levels for relay and ballast channels.
Switch-on level	Set switch-on levels for SDIM/DMX channels.
Hysteresis	Activate / De-activate SDIM hysteresis for relay and ballast channels.
LCD contrast	Adjust the LCD contrast level.
LCD timeout	Activate / De-activate the LCD display timeout function.
Factory reset	Reset all settings to factory defaults.
Use password	Apply password lock to settings (except to ‘Unit details’ and ‘Enter password’ items).
Enter password	Remove the password lock (see ‘Use password’)

Menu options details

Addresses

The digital interface (DALI or SDIM/DMX) receives control messages from devices in the system. You can set any address to any channel.

Note: *The base address is the first channel address, from which the remaining addresses are allocated (unless changed manually in the address submenu).*

Submenu items	Options
SDIM/DMX mode	DMX or SDIM (Default)
SDIM/DMX base	SDIM base: 1–247 (Default: 1) DMX base: 1–505
SDIM/DMX addr	Channel: 1–8 SDIM address: 1–254; Disabled (Default: 1) DMX address: 1–512; Disabled (Default: 1)
DALI base	DALI Base: 1–57 (Default: 1)
DALI addresses	Channel: 1–8 Address: 1–64; Removed; Disabled Removed: Next time you connect it to a controller program or router, the DALI address will be reallocated. Disabled: The address will not be reallocated.

Ballast output

Submenu items	Options
Status (read-only)	---- = No ballast outputs present.
Refresh	Rechecks status of ballast outputs.
Channel pairs	Ballast Channel: 1–8. Relay Channel: 1–8; Separate By default, relay channels 1–8 are paired with outputs 1–8. Changing the levels of relay channels 1–8 affects the levels of outputs 1–8 accordingly.
Output mode	Channel: 1–8; ALL (Default: 1) Mode: 0: 0/10 V 1: 1–10 V sink 2: 0–10 V 3: PWM+ 4: PWM– 5: DALI b'cast [DALI broadcast] 6: DSI® 7: [Off]

Unit details

Submenu items	Options
Details (read-only)	Serial number and Firmware version
Mode	Mode, power and data information If DALI power is on, a tick appears next to the DALI power field. DALI or SDIM/DMX shows the last detected mode when the module was reset.
Relay contacts (read-only)	Heatsink and internal temperatures
User mode (all read-only);	For message details, refer to 'Error messages' on page 15.

Recall scene

Recall a scene previously stored (temporarily if connected to a Helvar router system).

Scenes are sets of lighting levels and can make use of any combination of channels.

This option is always available, even when password protection is applied to other options.

Range: Scene 1–16

Save as scene

The levels that are currently active for all channels are applied to this scene. You can recall stored scenes in the 'Recall Scene' menu (see above).

Range: Scene 1–16

Default scenes

Default lighting scenes can be applied to the output channels, i.e. scene 1 = 100 %, scene 2 = 75 %, scene 3 = 50 %, and scene 4 = 25 %.

Note: *Lighting levels are NOT changed automatically once you apply default scenes. However, once you recall a scene, lighting is set to the levels for that scene.*

Groups

Assign relay and ballast output pairs to DALI groups. Any relay/output pair can be assigned to any group.

Options:

Group: 1–16
 Relay and output: 1–8
 Options: (Up button);
 x (Down button).
 (Default: xxxxxxxx)

Min. fade time

Set the minimum time it takes to change between minimum and maximum lighting levels.

Options:

Channel: 1– 8,
ALL

Fade time: 0: 20 ms
1: 150 ms
2: 500 ms
3: 1 s (Default)

Power on level

Set the level each channel will go to when the unit is powered on, with DALI connected.

Note: *Power-on levels for SDIM are set in the router or TouchPanel (not with the Control Panel).*

Options:

Channel: 1–8;
ALL

Power on level: 0 % – 100 %;
Last
(Default in DALI mode: 100 %)

Failure level

Set channel levels for situations where the DALI bus goes low, such as when it is short-circuited or when the DALI PSU is turned off.

Options:

Channel: 1–8;
ALL

Failure level: 0 % – 100 %; **** (= do not apply Failure level); (Default:100 %)

Override level

If the override input connection is short-circuited, e.g. by contact closure on an alarm system, all channels are set to their override level, regardless of external control signals.

Options:

Channel: 1–8;
ALL

Override level: 0 % – 100 %; **** (= do not apply override level); (Default:100 %)

Minimum level

Set the minimum DALI lighting level the channel will achieve when turned on, no matter what scene is called or level is set.

For example, if you set a minimum level of 50 % and call scene 4 (at 25 % level), the channel output level will be 50 %.

For SDIM/DMX, the level set here is actually the switch-on level, and the channel will not turn on unless it receives a command to go to or above this level.

Options:

Channel: 1–8;
ALL

Minimum level: 0.1 %; 1 % – 100 %; (Default: 0.1 %)

Switch-on level

Set the switch-on levels for SDIM/DMX channels.

Options:

Channel: 1–8;
ALL (Default)

Switch-on level: 0 % – 64 %; (Default: 2 %)

Hysteresis

Note: *Hysteresis is supported only when controlled by SDIM.*

This setting affects the level at which the channel turns off. When hysteresis is on, the switch-off level is 80 % of the switch-on level. At or below the switch-off level, the channel will be off. For example, if the switch on level is 50 %, and the signal rises to this level or above, the channel will turn on. Then if the signal falls to 40 % or below, the channel will turn off.

By default:

- When hysteresis is on and the signal rises to 2 %, the lighting for that channel turns on; when it falls to 0 %, the channel turns off.
- When hysteresis is off (default setting) and the signal rises to 2 %, the lighting for that channel turns on; when it falls to 1 %, the channel turns off.

Options:

Channel: 1–8;
ALL

Off: (up button);
x (down button)
(Default: x)

LCD contrast

Set the LCD display contrast: 0 % – 100 % (default: 40 %)

Note 1: *Even at 0 %, the text is just visible.*

Note 2: *The display adjusts as you raise or lower the contrast value, but you must press 'OK' to select that contrast level.*

LCD timeout

When the LCD timeout is on, after 60 seconds of inactivity on the Control Panel, the back-light on the Control Panel LCD Display dims down and the Control Panel is then in standby mode.

Options:

Timeout: (up button);
 x (down button)
 (Default: = yes)

Factory reset

Reset the module to the original settings (defaults).

Note: *Restoring factory settings returns all connected lighting to default levels immediately.*

Press and hold 'OK' for 10 seconds until a ' Done' message appears.

Use password

Note: *The password is disabled by default.*

You can use the factory-set password for the module.

If the password is enabled, you must enter the correct password; otherwise you can only use the following functions/ menus:

- Change output levels
- View technical information about the module
- Recall a scene
- Enter the password

If you chose to use the password, after one minute of inactivity the Control Panel goes to standby and the 'Enter password' menu appears in 'Main menu'.

'Use password' disables the functionality of the remaining menus. You can access the menus but cannot change any settings unless you enter the password . The password is '58' (without the quotation marks).

When you enter the menu, a key  is displayed in the bottom right of the screen to indicate that you cannot enter any settings.

Options:

Use password:
 (up button);
 x (down button)
 (Default: **x** = no)

Press 'OK' to confirm the new selection, and a ' Done' message appears.

The password lock will be applied after a period of 60 seconds from this message appearing.

Enter password

If the password is enabled and you want to use all the functions of the module, you must enter the correct password.

Error messages

If an error occurs, a flashing message will appear at the top of the Control Panel LCD Display.

The following table lists these error messages and their meanings:

Message	Reason	Output	Trip	Notes
Override On	Override input pulled low	Override level	-	User can change override levels on the fly (unless locked)
Comms Error	SDIM communications error, e.g. two units with the same SDIM address, or incorrect SDIM/DMX mode selection.	-	-	-
Ballast O/P	458/OPT4 options module connected.	-	-	The 458/OPT4 module should not be connected.

Dimensions (mm)

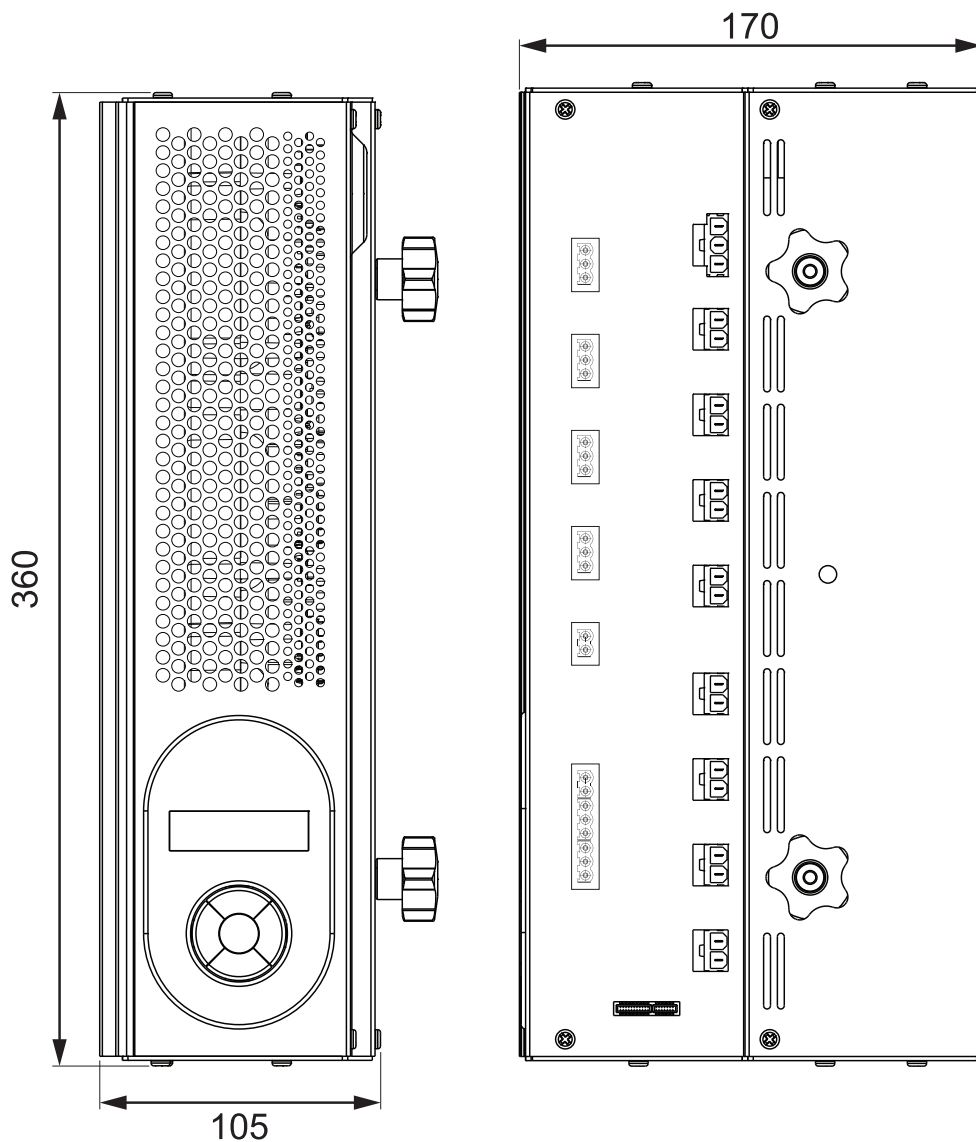

Technical specifications

Connections

DALI:	0.5 mm ² – 1.5 mm ² (max. 300 m @ 1.5 mm ²)
SDIM/DMX:	0.22 m ² – 1.5 mm ² low-loss RS485 Type (multistranded, twisted and shielded)
Override (OVR):	0.5 mm ² – 1.5 mm ² (screened and twisted)

Relay

Relay contacts:	High inrush, single pole, single throw (SPST), normally open (NO), volt-free
Voltage:	400 VAC
Max. load per contact:	16 A resistive/incandescent, 10 A HID (cos γ = 0.6). <i>Note: For ballasts, quantity is limited by MCB: refer to manufacturer's data. External protection must not exceed 16 A type C MCB.</i>

Outputs

0–10 V:	Source 20 mA
1–10 V (50 ballasts):	Sink 100 mA
DALI/DSI® (50 ballasts):	Source 100 mA
PWM +/- (50 ballasts):	Source 100 mA

Power

Mains supply:	100 VAC – 240 VAC (nominal) 85 VAC – 264 VAC (absolute) 45 Hz – 65 Hz
---------------	---

Power consumption:	1.2 W (excluding loads)
--------------------	-------------------------

Protection

Power circuit protection:	6 A max. external protection, earth mandatory
Thermal protection:	Control board – resettable fuse

Installation

Mounting:	Attached to 458M1, 458M2, or 458M3 chassis
-----------	--

Mechanical data

Dimensions:	105 mm × 360 mm × 170 mm
Housing:	Powder coated steel (black)
Weight:	2.2 kg
IP code:	IP20

Operating conditions and storage

Ambient temperature:	0 °C to +40 °C
Relative humidity:	Max. 90 %, noncondensing
Storage temperature:	-10 °C to +70 °C

Conformity and standards

EMC emission:	EN 55015
EMC immunity:	EN 61547
Safety:	EN 61347-2-11
DALI data transfer:	According to DALI standard IEC 60929, with Helvar extensions
SDIM data:	Helvar protocol (RS485, 115 kbps)
DMX data:	DMX512-A protocol (max. refresh rate: 33 Hz)
Environment:	Complies with WEEE and RoHS directives.

