

950 Application controller Installation Guide

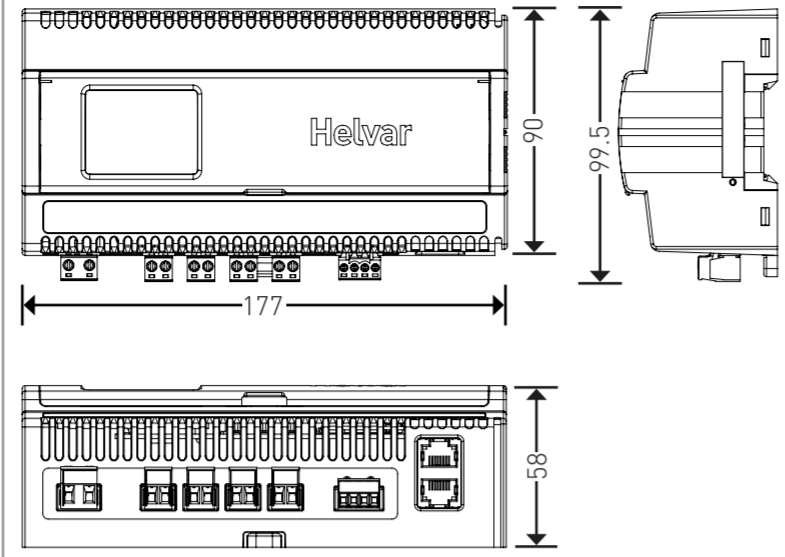

Dimensions (mm) / Mitat (mm) / Mått (mm) / Dimensions (mm) / Abmessungen (mm) / Dimensioni (mm)



Fitting / Asennus / Fastsättning / Installation / Anbringen / Montaggio

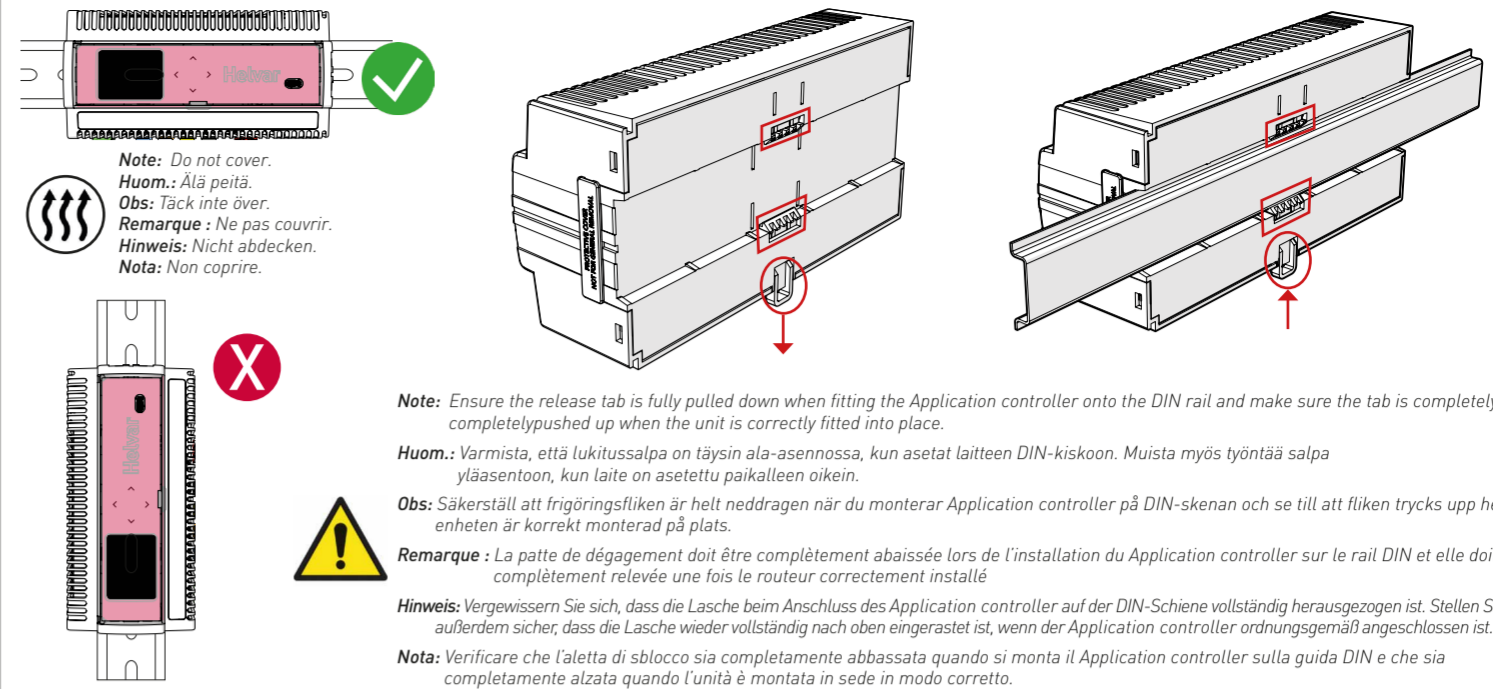

Connections / Liitännät / Anslutningar / Connexions / Anschlüsse / Connessioni



OFF / POIS / AV /
ÉTEINTE / AUS / SPENTO

Note: Does not need an earth connection.
Huom.: Ei tarvitse maadoitusliitintää.
Obs: Behöver ingen anslutning till jord.
Remarque: Mise à la terre non requise.
Hinweis: Keine Erdung erforderlich.
Nota: Messa a terra non necessaria.

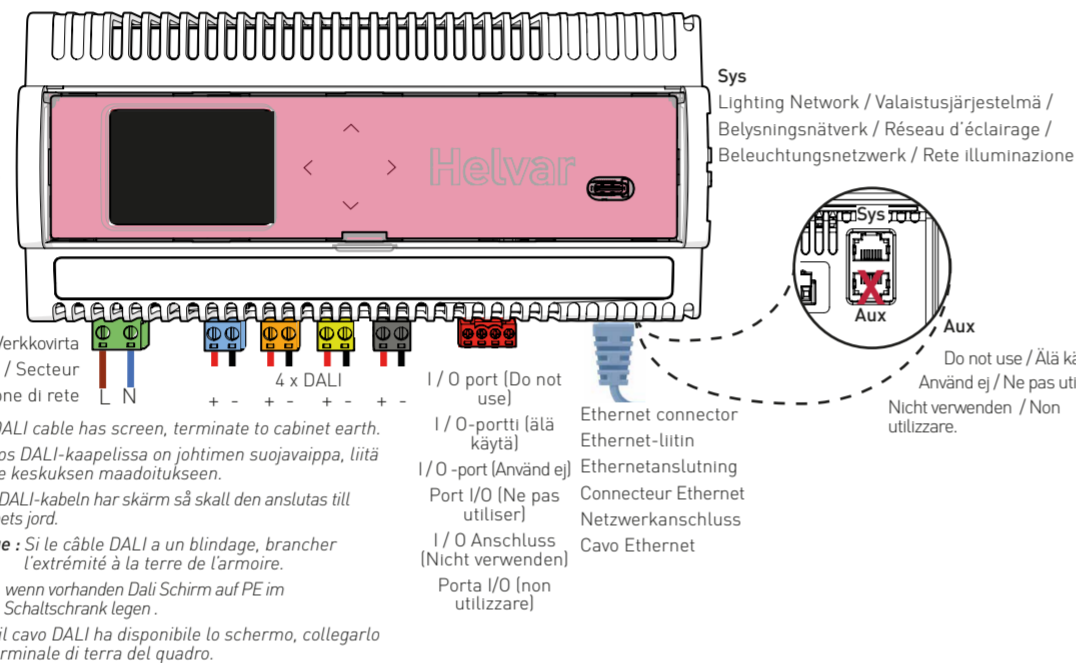

Features / Ominaisuudet / Funktioner / Fonctions / Ausstattung / Caratteristiche

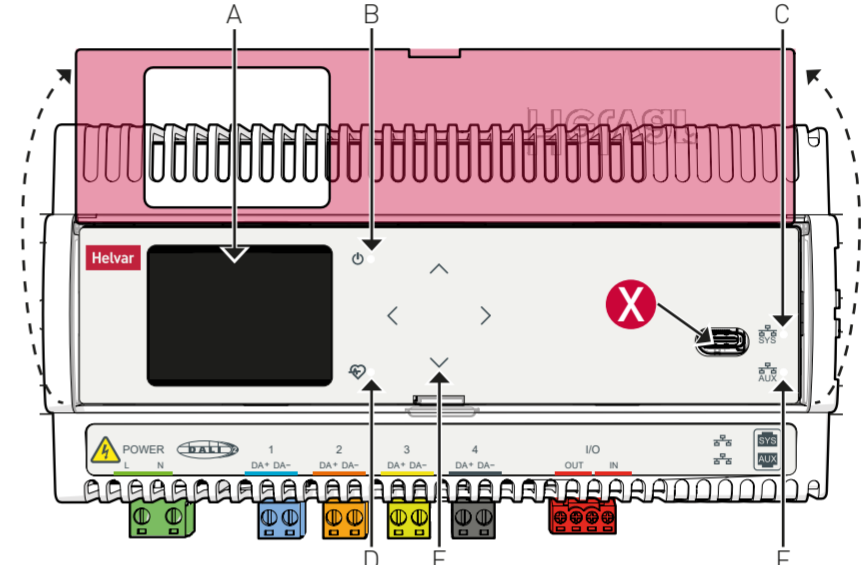

A - LCD screen / LCD-näyttö / LCD-skärm / Écran LCD / LCD-Bildschirm / Schermo LCD.
B - Power On Indicator / Virta päällä-merkkivalo / PÅ-indikator / Voyant d'alimentation / Betriebszustands LED / Indicatore accensione.
C - SYS network indicator / SYS-verkon merkkivalo / SYS-nätverksindikator / Voyant de réseau SYS / SYS Verbindungs-LED / Indicatore rete SYS.
D - System heartbeat / Järjestelmän syke / Systempuls / État du système / System Status LED / Monitoraggio sistema.
E - LCD screen buttons / LCD-näytön painikkeet / LCD-skärmknappar / Boutons de l'écran LCD / Tasten LCD-Bildschirm / Pulsanti schermo LCD.
F - AUX network indicator / AUX-verkon merkkivalo / AUX-nätverksindikator / Voyant de réseau AUX / AUX Verbindungs-LED / Indicatore rete AUS.

Ethernet Connection / Ethernet-liitin / Ethernetanslutning / Connexion Ethernet / Netzwerkanschluss / Connessione Ethernet

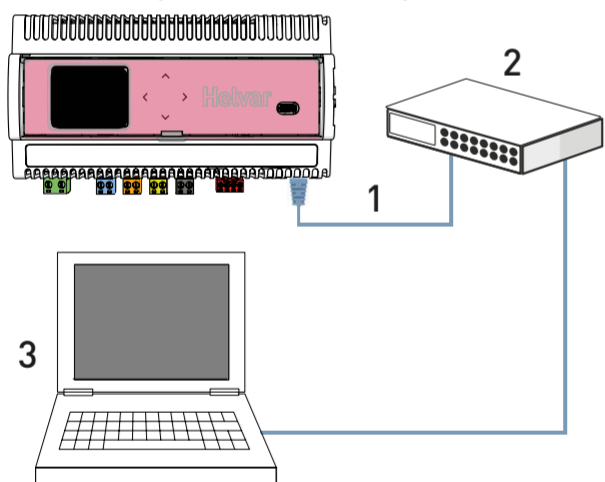

- EN** 1 = Ethernet cable, e.g. CAT 5 (E)
2 = Hub, switch or network router
3 = Computer
- DE** 1 = Netzwerkabel z.B. CAT 5 (E)
2 = Hub, switch oder Router
3 = Computer
- FI** 1 = Verkkoakaappeli esim. CAT 5 (E)
2 = Keskitin, kytkin tai reititin
3 = Tietokone
- FR** 1 = Câble Ethernet, e.g. CAT 5 (E)
2 = Hub, switch ou routeur réseau
3 = Ordinateur
- SV** 1 = Ethernet kabel (ex. CAT 5)
2 = Hub, switch eller nätverksrouter
3 = Dator
- IT** 1 = Cavo Ethernet es. CAT 5 (E)
2 = Hub, switch o router di rete
3 = Computer

LED Status Table / LED-tilataulukko / LED-statustabell / Tableau du statut des LED / LED-Statustabelle / Tabella stato LED



| | | | |
|--|---|---|---|
| Power/Virta/Ström/Alimentation / Betriebszustand / Alimentazione | Blue = Power Up / Sininen = Käynnisty / Blå = Starter Bleu = Démarrage / Blau = Hochfahren / Blu = Accensione | Green = Power On / Vihreä = Virta päällä / Grön = Ström på / Vert = Sous tension / Grün = in Betrieb / Verde = Alimentazione attiva | Red = Shutting down / Punainen = Sammuu / Rod = Stänger av / Rouge = Arrêt / Rot = Herunterfahren / Rosso = Arresto |
| Heartbeat / Syke / Puls / État / Status / Monitoraggio | Green (Blinking) = Good health / Vihreä (vilkkuu) = Kunnossa / Grön (Blinkar) = Fungerar bra / Vert (clignotant) = Bon état / Grön (blinkend) = Status ok / Verde (lampeggiante) = Condizioni buone | | |
| USB C OTG | For developer use only / Vain kehittäjän käyttöön / Endast för utvecklare / Utilisation réservée au développeur / Nur zur Verwendung durch Entwickler / Solo per uso dello sviluppatore | | |

| | |
|----------|--|
| Ethernet | |
| LED | |
| ● | No connection / Ei yhteyttä / Ingen anslutning / Pas de connexion / Keine Verbindung / Nessuna connessione |
| ○ | Link / Linkki / Länk / Liaison / Link / Collegamento |
| ◐ | Activity / Aktivinen / Aktivitet / Activité / Aktivität / Attività |

Display Navigation Guide / Käyttöliittymän pikaopas / Skärmenavigeringsguide / Guide de navigation de l'affichage / Display-Navigationshilfe / Guida de navigation de l'affichage

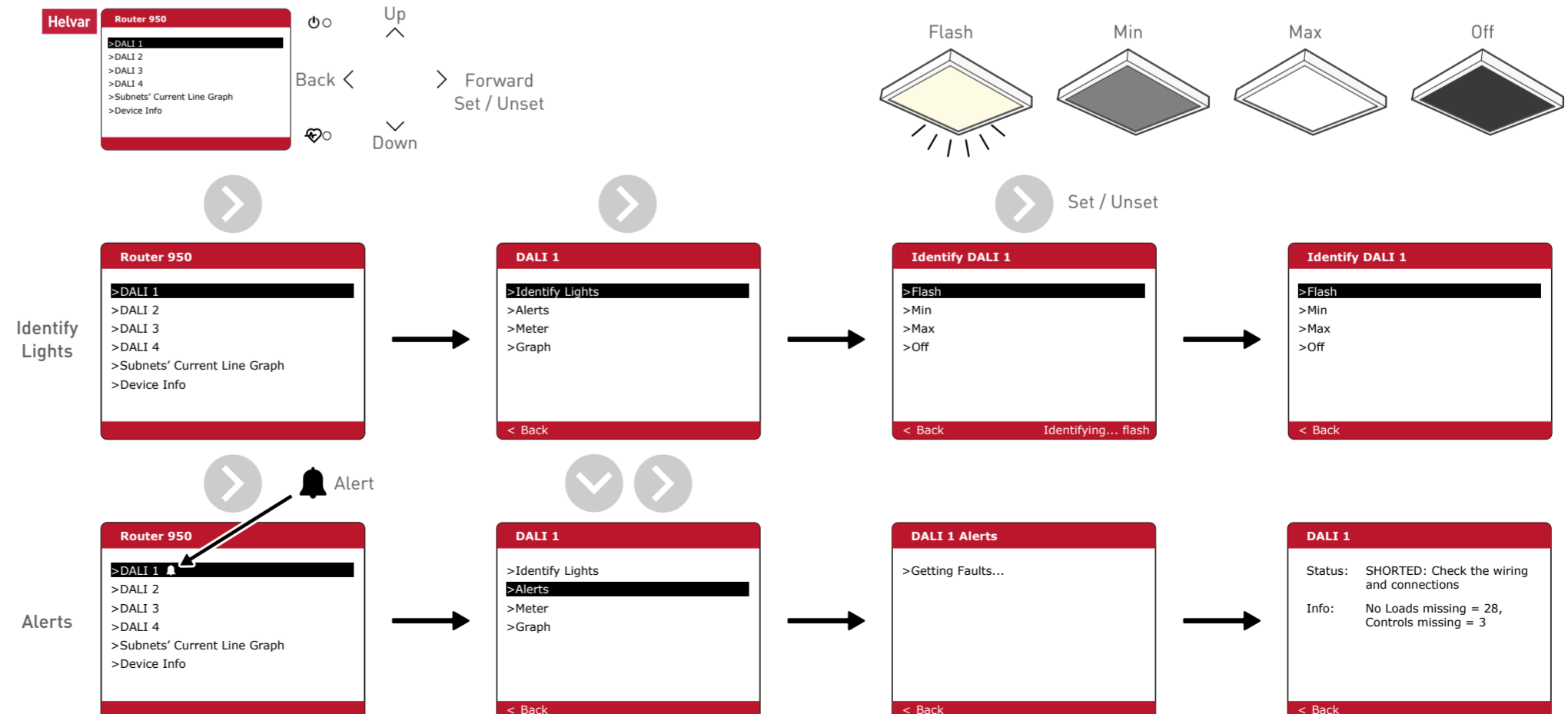

FI 950 reititin Asennusopas

SV 950 Application Controller Installationsmanual

FR Guide d'installation du Application Controller 950

DE 950 Application Controller Installationshandbuch

IT Application Controller 950 Guida all'installazione

Helvar Ltd,
Hawley Mill, Hawley Road,
Dartford. DA2 7SY. UK
www.helvar.com
+44 (0) 1322 617200

Helvar Oy Ab
Keilaranta 5, 02150, Espoo, Finland
www.helvar.com
+358 9 5654 1

