

458/SW8 Installation and User Guide



Introduction

The 458/SW8 is a 8-channel switching module. It uses high inrush relays to withstand short-lived high peak current inrush when switching on loads. It has both a DALI and an S-DIM/DMX interface, and therefore can be fully integrated into a Digidim or an Imagine router system.

NOTE: DALI AND S-DIM / DMX MUST NOT BE CONNECTED SIMULTANEOUSLY.

Chassis modules

The 458/SW8 module is attached to the 458M1, 458M2 or 458M3 chassis. The chassis modules are supplied with control module by-pass connectors, and can be fully installed and wired prior to fitting of the control module(s). This allows for all electrical installation, testing and powering up of the lighting circuits to be carried out prior to the fitting of the control modules. This prevents possible damage to the control modules due to circuit overload or faults, or the use of high voltage insulation testing equipment.

LCD display and keypad

The front of the module is equipped with an LCD display and keypad to set basic configuration parameters and provide basic control of channel and output levels.

Channels and load protection

The module has 8 relay channels (normally open), capable of switching 16A per channel.

Note: the correct chassis load protection must be chosen to ensure the required channel ratings are achieved, but not exceeded.

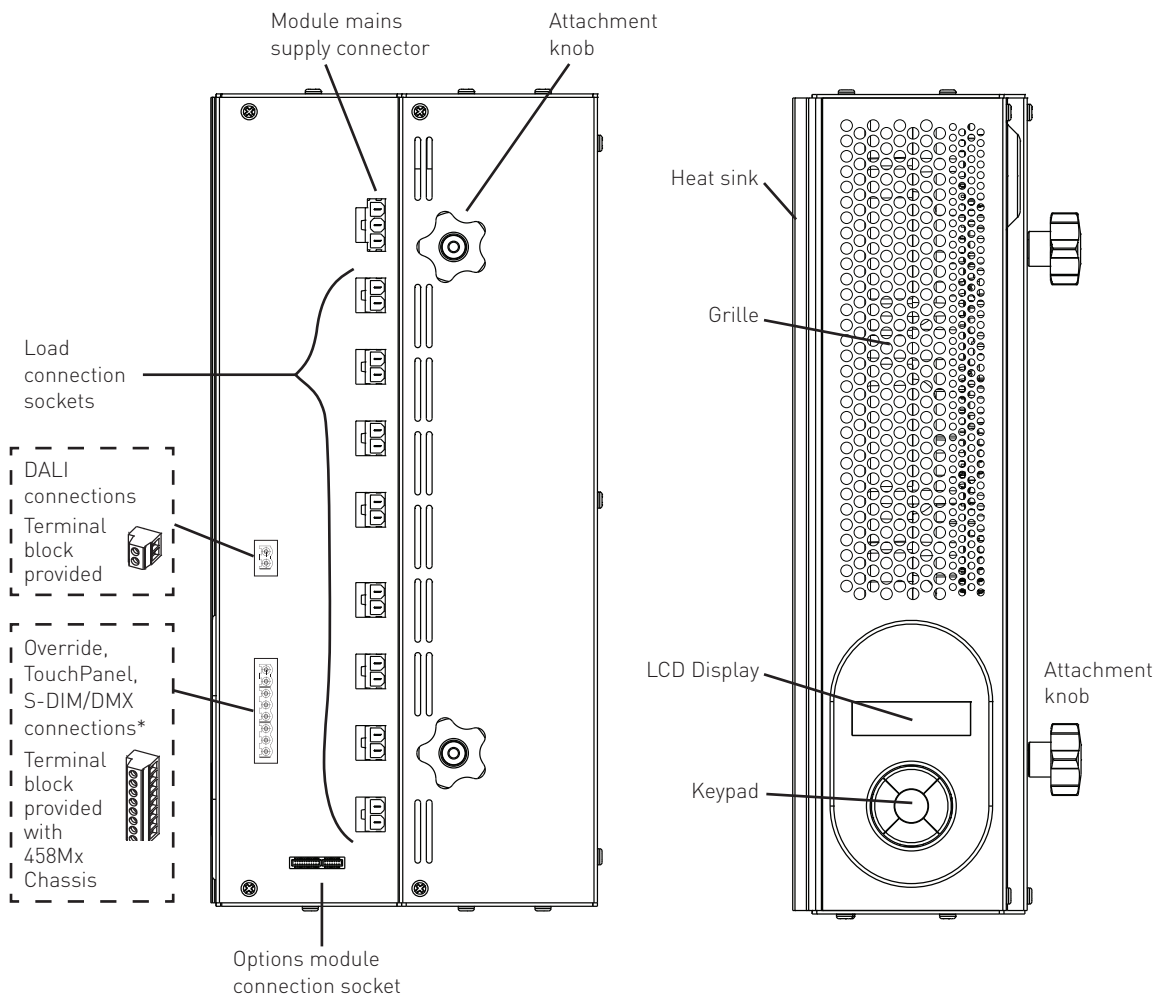

Installation

1. Attach the module to a chassis

Mounting, Environmental and Clearance Requirements

Mounting

- Attach the 458/SW8 to a 458M1, 458M2, or 458M3 chassis, which is mounted vertically on a flat surface.

Environment

- The ambient temperature must be between 0°C and 40°C.
- Air humidity must be between 0% and 90% (non-condensing).
- The area must be adequately ventilated.
- Do NOT install this product in a damp location.

Clearance

- For effective ventilation, ensure that there is adequate space around the combined chassis and module(s): 50 mm above, below and on both sides. Refer to the mounting dimensions and clearance diagrams in the 458Mx Chassis Installation Guide.
- When a Helvar control module (e.g. 458/SW8) is attached, the grilles must NOT be obstructed.

Refer to the Helvar 458Mx Chassis Installation Guide for further information.

WARNING: BEFORE ATTACHING THE MODULE AND MAKING ANY CONNECTIONS, ENSURE THAT THE MAINS SUPPLY IS ISOLATED.

IMPORTANT: The module may be controlled by either DALI or S-DIM/DMX, but DALI AND S-DIM / DMX MUST NOT BE CONNECTED SIMULTANEOUSLY.

1.1 Remove chassis cover

Refer to the 458Mx Chassis Installation Guide for details.

1.1 Remove chassis blanking plates

Unscrew and remove blanking plate(s) from the chassis.

Note 1: 458M1: 1 blanking plate;
458M2: 2 blanking plates;
458M3: 3 blanking plates.

Note 2: The diagrams on this page show the 458M1/4S10 Chassis.
Covers and knockouts are removed from the 458M2 and 458M3 in a similar way.

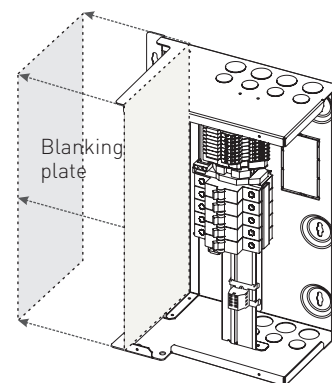

1.2 Loosen attachment knobs

Partially unscrew the two knobs on the module to reveal the pins.

1.3 Slot module pins into mounting bracket

Attach the module to the chassis by slotting the pins of the module to the mounting bracket.

1.4 Tighten knobs

Screw the knobs to the mounting bracket to secure the module.

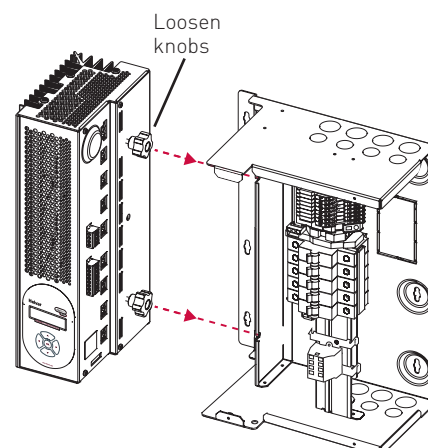

2. Connect power and load cables to module sockets

Connect the mains control supply as shown below. The load output cables from the 458M chassis will be plugged into the chassis bypass terminals. Unplug the cables, and connect them to the module channel terminals.

Note: The diagram on this page show the 458M1 chassis. Cable connection is similar for the 458M2 and 458M3.

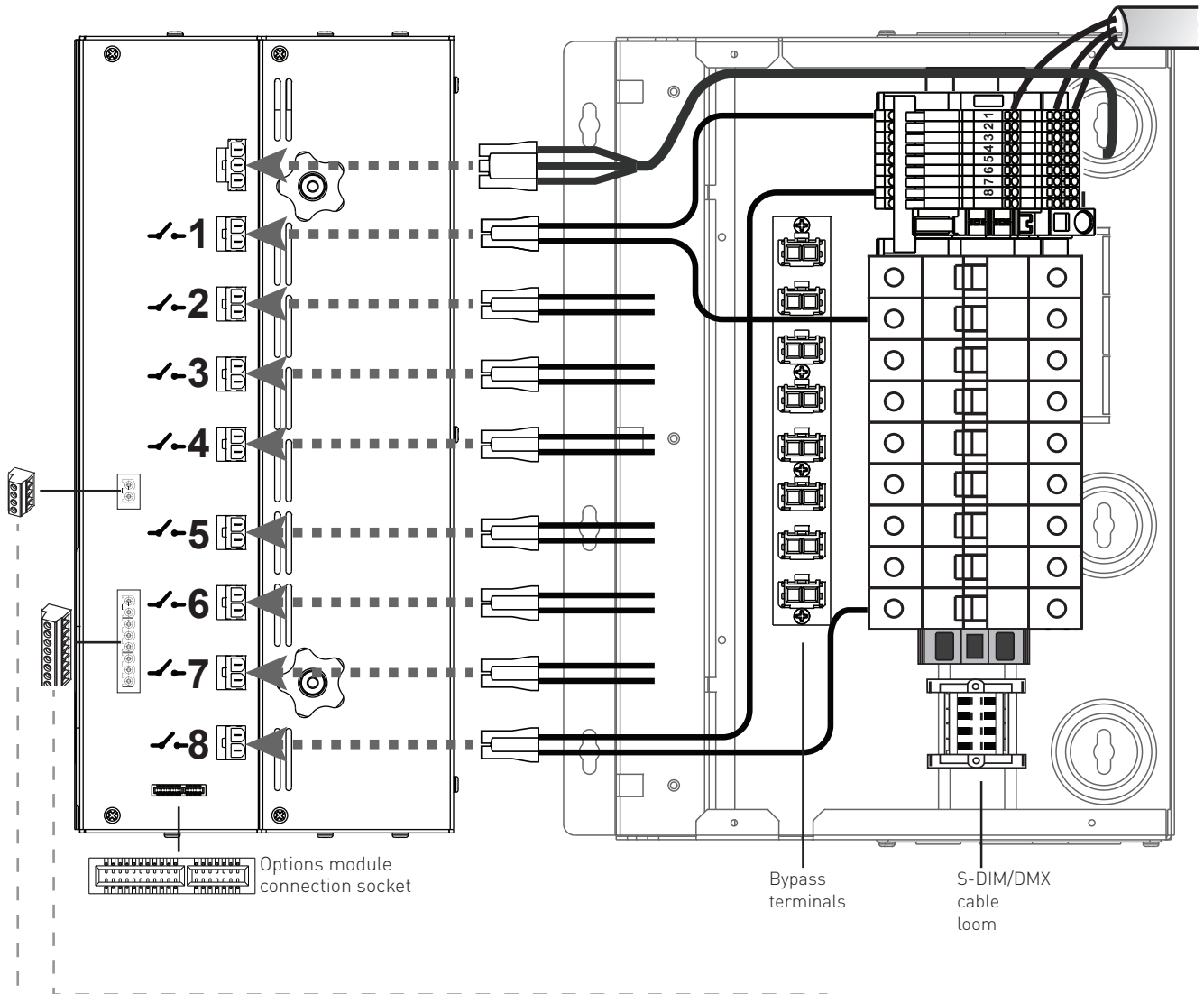

-- DALI connections

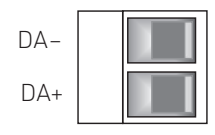

Override, S-DIM/DMX connections

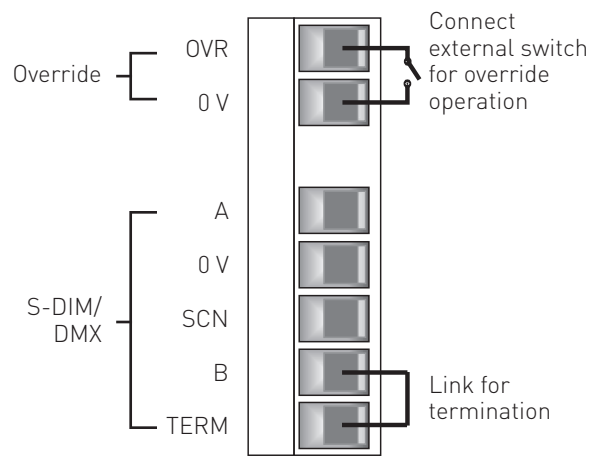

3. Make control connections

Refer to the connection diagrams on the previous page.

Ensure that all the necessary control connections have been made correctly and securely.

IMPORTANT:

ENSURE SEGREGATION BETWEEN MAINS CABLING AND OTHER CONNECTIONS.

DALI AND 1 – 10 V BALLAST CONNECTIONS SHOULD BE CONSIDERED AS POTENTIALLY LIVE.

3.1 DALI connections

If connecting to a Digidim system, use the DA+ and DA- terminals of the DALI connector.

3.2 Override connections

If you wish to provide output level override functionality, wire a switch between the '0 V' and 'OVR' terminals of the S-DIM or DMX connector. Switch closure sets the light level of all output channels to the override level.

3.3 S-DIM and DMX connections

If connecting to a Helvar Imagine system, plug in the connector of the S-DIM/DMX cable loom to the S-DIM/DMX terminals. This is attached to the DIN-rail inside the chassis.

If the module is at the end of the S-DIM/DMX cable, wire a link between the 'TERM' and 'B' connections of the S-DIM/DMX terminals to enable the cable termination.

4. Replace chassis cover

Replace the chassis cover, using the original screws.

5. Power on the unit

Power up the module by switching on the MCBs. The LCD display should appear as shown.

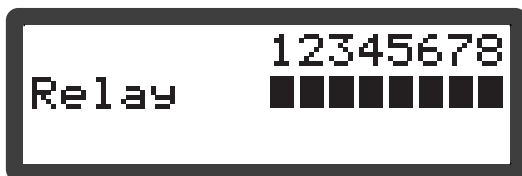

Start-up screen of module LCD display

Control Panel

Control Panel Functions

The control panel is used to view and adjust:

- relay and output channel levels
- various relay and options module settings

S-DIM connection

Example: to Helvar 920 Routers, or to Helvar TouchPanel.

Adjust these parameters using the control panel:

Channel pairing (if 458/OPT4 options module connected)

S-DIM addresses

Other parameters can be set using Designer software

DMX connection

Example: to Helvar 920 Routers, or to third party lighting desk.

Adjust these parameters using the control panel:

DMX addresses

Channel pairing (if 458/OPT4 options module connected)

Minimum fade time

Override level

Switch-on level

Other parameters can be set using Designer software

DALI connection

Example: to Helvar 920 Routers.

Adjust these parameters using the control panel:

Channel pairing (if 458/OPT4 options module connected)

Minimum fade time

Output mode

Override level

Other parameters can be set using Designer software

DALI standalone connection with Toolbox software

Adjust these parameters using the control panel:

Channel pairing (if 458/OPT4 options module connected)

Minimum fade time

Output mode

Override level

Other parameters can be set using Toolbox software

DALI standalone connection

This allows basic, 'out of box' scene recall, modify and store from DALI control panels. Other settings can be changed using the module control panel.

Note:

If S-DIM or DMX is connected and you change lighting levels or recall scenes on the control panel, then, after a short period of time, the levels revert to those being sent by the S-DIM/DMX master.



Control panel LCD display

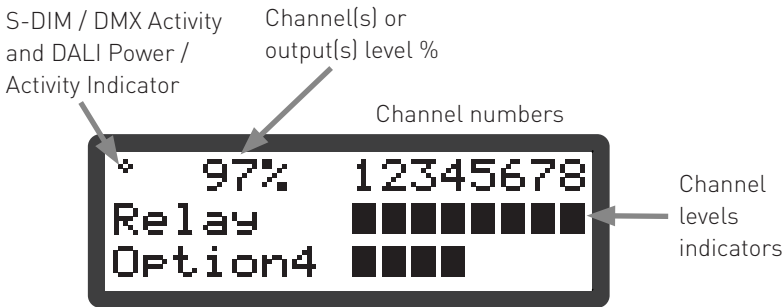

If the Options module is connected, output channel levels are displayed

S-DIM / DMX Activity and DALI Power / Activity Indicator:

This indicator in the top left-hand corner of the 'Display Screen' indicates S-DIM/DMX activity or DALI power / activity: For S-DIM / DMX it is normally off, and flashes on intermittently for activity. If DALI power is on, then the indicator is on. It flashes to indicate DALI activity.

Channel / Output level %

The percentage shown is the level of the currently selected channel(s) or output(s). 'ALL' is displayed here if all channels or outputs are selected simultaneously, but are set to different levels.

LCD Display Main Screen

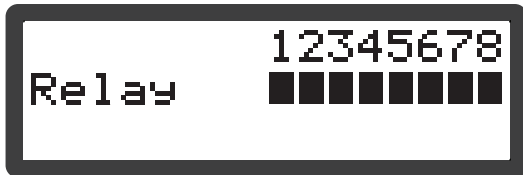

Main screen

The Main Display Screen appears:

- When the 458/SW8 is powered on
- After 60 seconds of inactivity on the Control Panel.
- After exiting the control panel options

Control panel keypad

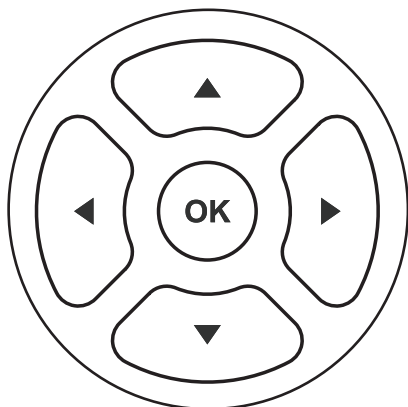



Use the keypad to:

- set output channel levels
- set output channel levels (if an Options Module is connected)
- navigate the system menus to adjust module settings



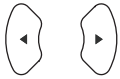
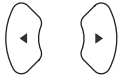



Adjusting channel and output levels using the keypad

Follow these steps to adjust channel and output levels

1.		(From the LCD Display Main Screen): Press either RIGHT or LEFT to access the relay and output (option) channel levels.
2.		Step left or right through channels / outputs The selected channel(s) or output(s) are shown by a flashing bar or 'o' (to indicate 0% light level).
3.		Adjust lighting level percentage (%) for the selected channel(s).
4.		Return to Main Display Screen

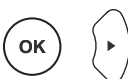
Navigating the menu using the keypad

Follow these steps to access and navigate the menus

1.		(From the LCD Display Main Screen): Press UP or DOWN to access the menu options.
2.		Scroll through main options.
3.		Select an option (access option screen).
4.		Adjust parameters.
5.		Step between different parameters in options screens
6.		Return to previous menu. Return to Main Display Screen (from main menu)

Physical selection

Physical selection mode allows loads and controls to be grouped together. It can be activated for a piece of equipment in a number of ways, including by using a Helvar remote control unit, or by using Designer or Toolbox software. Refer to the equipment instructions for details.

Follow these steps to use the module to identify a piece of equipment using physical selection mode.

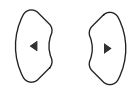
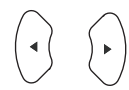
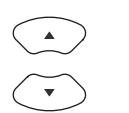
1.	-	Put the piece of equipment (e.g. router, sensor etc) into 'physical selection mode' (refer to the manufacturer's instructions)
2.		(From LCD display main page): Press either RIGHT or LEFT to access the relay and output channel levels.
3.		Step left or right through channels to select the channel to be used for physical selection.
4.		Press UP or DOWN to physical select the channel
5.	-	Repeat steps 3 and 4 for each channel, as necessary.
6.	-	Once identified, end 'Physical selection mode' for the piece(s) of equipment (refer to the manufacturer's instructions)

Module Menu Options

Main Menu

Use the keypad to access and navigate and adjust the menu options: see 'Navigating the menu using the keypad.'
 Below is a table listing the main options available from the module control panel. Full options details are listed in the next section.

Addresses	Set S-DIM, DMX and DALI addresses, including base addresses, and S-DIM/DMX mode.
Ballast output	View and refresh ballast status; pair relay and ballast channels; set output mode.
Unit Details	View module serial number, firmware version, and various other service-related information.
Recall scene	Recall DALI scenes.
Save as scene	Save levels as a DALI scene.
Default scenes	Reset DALI scenes to default settings.
Groups	Group and ungroup relay and ballast channels.
Min fade time	Set minimum fade times for relay and ballast channels.
Power on level	Set DALI power-on levels for relay and ballast channels.
Failure level	Set (or disable) DALI failure levels for relay and ballast channels.
Override level	Set (or disable) override levels for relay and ballast channels.
Minimum level	Set DALI minimum load levels for relay and ballast channels.
Hysteresis	Activate / De-activate S-DIM hysteresis for relay and ballast channels.
LCD contrast	Adjust the LCD contrast level.
LCD timeout	Activate / De-activate the LCD display timeout function.
Factory reset	Reset all settings to factory defaults.
Use password	Apply password lock to settings (except to 'Unit details' and 'Enter password' items).
Enter password	Remove the password lock (see 'Use password')

Menu Options Details

Addresses

The digital interface (DALI or S-DIM/DMX) receives control messages from devices in the system.

You can set any address to any channel.

Note: The base address is the first channel address, from which the remaining addresses are allocated (unless changed manually in the address sub-menu).

Sub-menu items	Options
S-DIM/DMX mode	DMX or S-DIM (Default)
S-DIM/DMX base	S-DIM Base: 1 – 247 (Default: 1) DMX base: 1 - 505
S-DIM/DMX addr	Channel: 1 – 8 S-DIM Address: 1 – 254; Disabled (Default: 1) DMX Address: 1 - 512; Disabled (Default: 1)
DALI base	DALI Base: 1 – 57 (Default: 1)
DALI addresses	Channel: 1 – 8 Address: 1 – 64; Removed; Disabled Removed: Next time you connect it to a controller program or router, the DALI address will be re-allocated Disabled: The address will not be reallocated

Ballast output

Sub-menu items	Options
Status (Read-only)	---- = No ballast outputs present
Refresh	Rechecks status of ballast outputs
Channel pairs	Ballast Channel: 1 – 4 Dimmer Channel: 1 – 4; Separate You can configure these settings only if there is an Options Module connected. Whilst paired with a dimmer channel, the dimmer channel will operate in switch mode.
Output mode	Channel: 1 – 4; ALL (Default: 1) Mode: 0: 0/10V 1: 1-10V sink 2: 0-10V 3: PWM + 4: PWM – 5: DALI b'cast 6: DSI 7: (Off)

Unit Details

Sub-menu items	Options
Details (Read-only)	Serial number and Firmware version
Mode	Mode, power and data information If DALI power is on, a tick appears next to the DALI power field. DALI or S-DIM/DMX shows the last detected mode when the module was reset.
Relay contacts (Read-only)	Heatsink and internal temperatures
User mode (All read-only);	Refer to the 'Troubleshooting' section of this guide for message details.

Recall Scene

Recall a scene previously stored (temporarily if connected to a Helvar router system). Scenes are sets of lighting levels and can make use of any combination of channels. This option is always available, even when password protection is applied to other options.
Range: Scene 1 -16

Save as Scene

The levels which are currently active for all channels are applied to this scene. You can recall stored scenes in the 'Recall Scene' menu (see above).
Range: Scene 1 -16

Default scenes

Default lighting scenes can be applied to the output channels, i.e. scene 1 = 100%, scene 2 = 75%, scene 3 = 50%, and scene 4 = 25%.

Note: Lighting levels are NOT changed automatically once you apply default scenes; but once you recall a scene, lighting is set to the levels for that scene.

Groups

Assign relay and ballast output pairs to DALI groups. Any relay/output pair can be assigned to any group.

Options:

Group: 1 – 16

Relay and output: 1 – 8

Options: ✓ (Up button);
x (Down button).
[Default: xxxxxxxx]

Min fade time

Set the minimum time it takes to change between minimum and maximum lighting levels.

Options:

Channel: 1 – 8, ALL

Fade time: 0: 20 ms
1: 150 ms
2: 500 ms
3: 1 sec (Default)

Power on level

Set the level each channel will go to when the unit is powered on, with DALI connected.

Note: Power-on levels for S-DIM are set in the router or TouchPanel, and not using the control panel.

Options:

Channel: 1 – 8;
ALL

Power on level: 0 – 100%;
Last
[Default in DALI mode:100%]

Failure level

Set channel levels for situations where the DALI bus goes low, such as when it is short-circuited or the DALI PSU is turned off.

Options:

Channel: 1 – 8;
ALL
Failure level: 0 – 100%;
*** (= do not apply Failure level);
[Default:100%]

Override level

If the override input connection is short-circuited, e.g. by contact closure on an alarm system, all channels are set to their override level, regardless of external control signals.

Options:

Channel: 1 – 8;
ALL
Override level: 0 – 100%;
*** (= do not apply override level);
[Default:100%]

Minimum level

Set the minimum DALI lighting level the channel will achieve when turned on, no matter what scene is called or level is set. For example, if you set a minimum level of 50% and call scene 4 (at 25% level), the channel output level will be 50%. For S-DIM/DMX, the level set here is actually the switch-on level, and the channel will not turn on unless it receives a command to go to or above this level.

Options:

Channel: 1 – 8;
ALL
Minimum level: 0.1%;
1% – 100%;
[Default: 0.1%]

Hysteresis

Note: Hysteresis is supported only when controlled by S-DIM.

This setting affects the level at which the channel turns off. When hysteresis is on, the switch-off level is 80% of the switch-on level. At or below the switch-off level, the channel will be off. For example, if the switch on level is 50%, and the signal rises to this level or above, the channel turns on, then if the signal falls to 40% or below, the channel turns off.

By default:

- When hysteresis is on and the signal rises to 2%, the lighting for that channel turns on; when it falls to 0%, the channel turns off.
- When hysteresis is off (default setting) and the signal rises to 2%, the lighting for that channel turns on; when it falls to 1%, the channel turns off.

Options:

Channel: 1 – 8;
ALL
Off: ✓ (up button);
x (down button)
[Default: X]

LCD Contrast

Set the LCD display contrast: 0–100% (default: 40%)

Note 1: Even at 0%, the text is just visible.

Note 2: The display adjusts as you raise or lower the contrast value, but you must press 'OK' to select that contrast level.

LCD timeout

When the LCD timeout is on, after 60 seconds of inactivity on the Control Panel, the back-light on the LCD 'Display Screen' dims down and the Control Panel is then in standby mode.

Options:

Timeout: ✓ (up button);
 x (down button)
 (Default: ✓ = yes)

Factory reset

Reset the module to the original settings (defaults).

Note: Restoring factory settings returns all connected lighting to default levels immediately.

Press and hold 'OK' for 10 seconds until , a '✓ Done' message appears.

Use password

Note: The password is disabled by default.

You can use the factory-set password for the module.

If the password is enabled, you must enter the correct password, otherwise you can only use the following functions / menus:

- Change output levels
- View technical information about the module
- Recall a scene
- Enter the password

If you chose to use the password, after 1 minute of inactivity, the Control Panel goes to standby and the 'Enter password' menu appears in 'Main Menu'.

'Use password' disables the functionality of the remaining menus. You can access the menus but cannot change any settings, unless you enter the password (58).

A key (🔒) is displayed in the bottom right of the screen when you enter the menu, to indicate that you cannot enter any settings.

Options:

Use password: (password is 58)
 ✓ (up button);
 x (down button)
 (Default: x = no)

Press 'OK' to confirm new selection, and a "✓ Done" message appears.

The password lock will be applied after a period of 60 seconds from this message appearing.

Enter password

If the password is enabled and you wish to use all of the functions of the module, you must enter the correct password.

Troubleshooting

Error messages

If an error occurs, a flashing message appears at the top of the LCD display screen. The table below lists these error messages and their meanings:

Message	Reason	Output	Trip	Notes
Override On	Override input pulled low	Override level	-	User can change override levels on-the-fly (unless locked)
Comms Error	S-DIM communications error e.g. two units with the same S-DIM address, or incorrect S-DIM/DMX mode selection.	-	-	-
Ballast O/P	458/OPT4 options module has been disconnected.	-	-	The 458/OPT4 module should be connected, or refresh ballast status.

Dimensions

Dimensions in mm

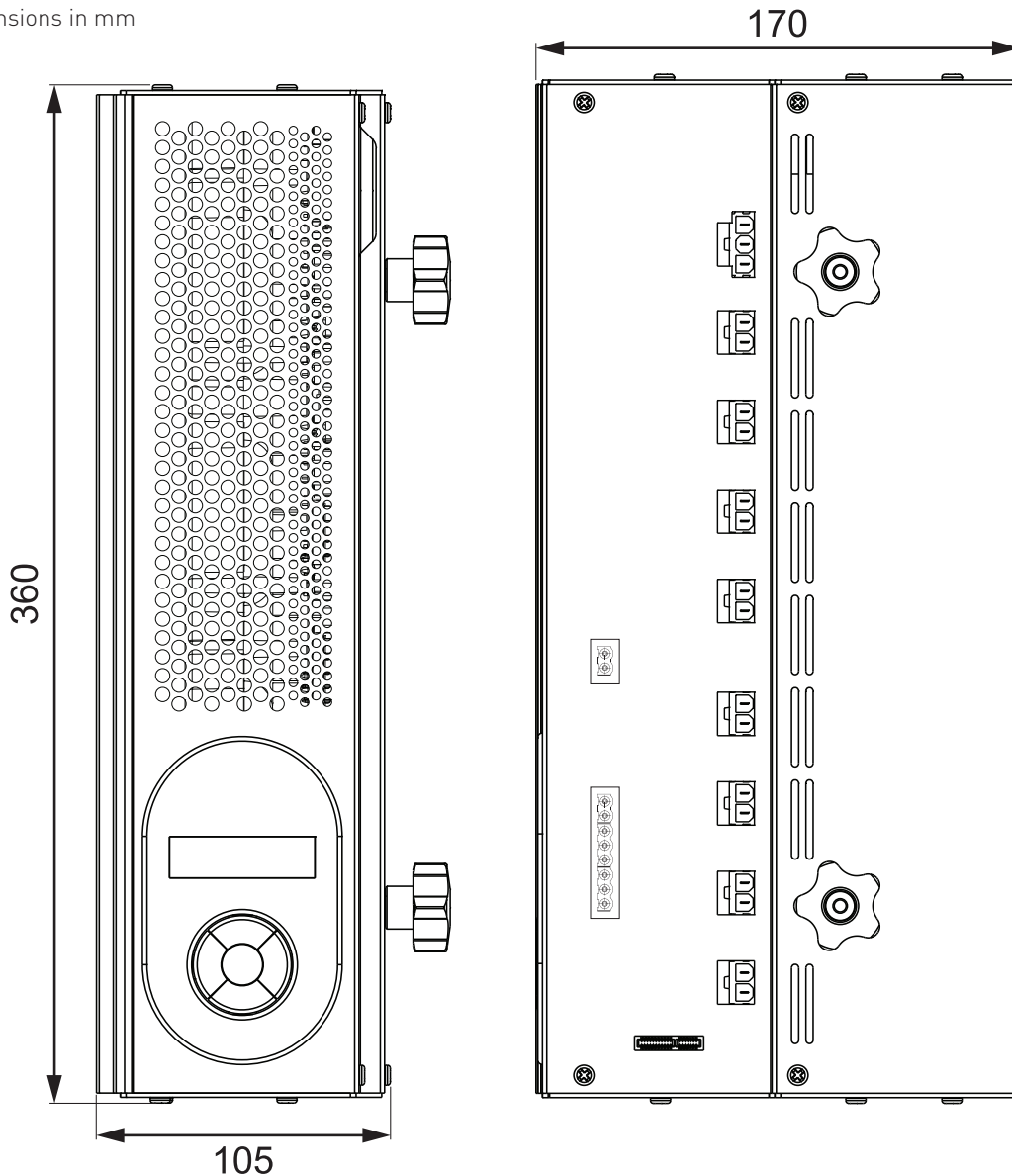

458/SW8 Technical Specifications

Connections

DALI:	0.5 mm ² - 1.5 mm ² (max. 300 m @ 1.5 mm ²)
S-DIM / DMX	0.22 mm ² -1.5 mm ² low loss RS485 Type (multi-stranded, twisted and shielded)
Override	0.5 mm ² to 1.5 mm ² (screened and twisted)
Relay contacts:	High inrush, single pole single throw (SPST), normally open (NO), volt-free
Voltage:	400 VAC
Isolation:	4 kV
Max. load per contact:	16 A resistive/incandescent, 10 A HID (cos ϕ =0.6)

For ballasts, quantity is limited by MCB: refer to manufacturer's data. External protection must not exceed 16 A type C MCB.

Power

Mains supply voltage:	85 VAC to 264 VAC, 45 - 65 Hz
Power consumption:	1.1 W (excluding loads)

Protection

Electrical protection:	6 A MCB and PTC for control board (MCB type C 10 kA) For load protection: refer to 458Mx installation guide.
Thermal protection:	Control board – resettable fuse

Conformity and Standards

EMC Emission:	EN 55015
Immunity:	EN 61547
Safety:	EN 60950
Isolation:	4 kV
IP rating:	IP 20
DALI data transfer:	According to DALI standard IEC60929, with Helvar extensions
S-DIM data transfer:	Helvar protocol (RS485, 115 kbps)
DMX data transfer:	DMX512-A protocol
Environmental:	Complies with WEEE and RoHS directives

Installation

Mounting:	Attached to 458M1, 458M2, or 458M3 chassis
-----------	--

Mechanical Data

Dimensions:	See diagram
Weight:	2.1 kg
Housing:	Powder coated steel (black)
Heatsink:	Anodised aluminium

Operating and Storage Conditions

Ambient Temperature:	0°C to 40°C
Storage Temperature:	-10°C to 70°C
Relative Humidity:	Max 90%, non-condensing

