

## 150 W **Constant Current** LED driver

Product code: 5729

150 W 220 – 240 V 0 / 50 – 60 Hz

- Very high efficiency up to 96%
- Low current ripple, complying with IEEE 1789 recommendation
- Improved driver surge protection (4 kV / 4 kV)
- Wider ambient temperature operation range
- Long lifetime up to 100 000 h
- Suitable for DC use
- Driver protection Class I
- Ideal solution for Class I luminaires, suitable for Class II luminaires too\*



\* See page 4 for details.



### Functional Description

- Adjustable constant current output: 350 mA (default) to 700mA
- Current setting with external resistors
- NTC terminal for overtemperature protection
- Open & short circuit protection

### Mains Characteristics

Nominal rated voltage range	220 V – 240 V, 0 / 50 – 60 Hz
AC voltage range	198 VAC – 264 VAC
	Withstands max. 320 VAC (max. 1 hour)
DC voltage range	176 VDC – 280 VDC
DC starting voltage	> 190 VDC
Mains current at full load	0.50 – 0.80 A
Frequency	0 / 50 Hz – 60 Hz
THD at full power	< 10 %
Leakage current to earth	< 0.3 mA
Tested surge protection	4 kV L-N, 4 kV L-GND (IEC 61000-4-5)
Tested fast transient protection	2 kV (IEC 61000-4-4)

### Insulation between circuits & driver case

Mains circuit - Output	Non-isolated
Mains and output - Driver case	Basic insulation

### Load Output (non-isolated)

Output current ( $I_{out}$ )	350 mA (default) – 700 mA
Accuracy	$\pm 5 \%$
Ripple	< 2 %* at $\leq 120$ Hz
	*] Low frequency, LED load: Cree XP-G LEDs
PstLM	< 0,08*
SVM	< 0.02*
	*] At full load, measured with Cree XP-G LED modules.
$U_{OUT}$ (max) (abnormal)	370 V

$I_{LED}$	350 mA	700 mA
$P_{RATED}$	122.5 W	150 W
$U_{LED}$	257 – 350 V	128 – 214 V
PF ( $\lambda$ ) at full load	0.98	0.98
Efficiency ( $\eta$ ) at full load	96 %	95 %

## Operating window

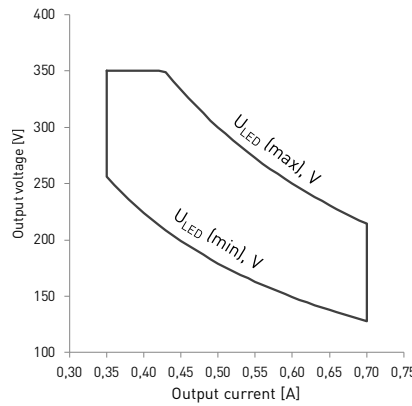

## Driver performance

Typical efficiency

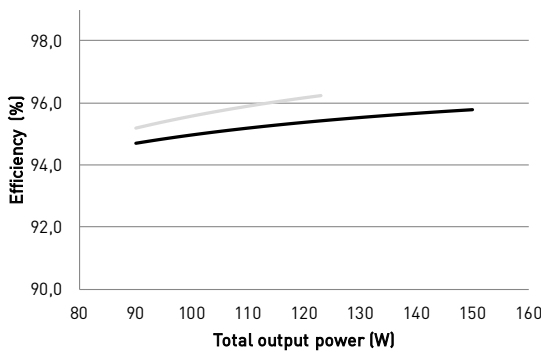

Typical power factor

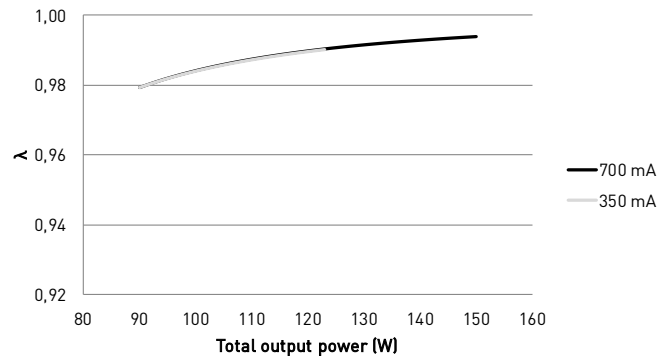

## Operating Conditions and Characteristics

Highest allowed $t_c$ point temperature*	90 °C
$t_c$ life (50 000 h) temperature	80 °C
Ambient temperature range*	-40 °C ... +60 °C
Storage temperature range	-40 °C ... +80 °C
Maximum relative humidity	No condensation
Lifetime (90 % survival rate)	100 000 h, at $t_c = 70$ °C 50 000 h, at $t_c = 80$ °C 25 000 h at $t_c = 90$ °C

*\*) For other than independent use, higher  $t_c$  of the control gear possible as long as highest allowed  $t_c$  point temperature is not exceeded*

## Quantity of drivers per miniature circuit breaker 16 A Type C

Based on inrush current $I_{peak}$	Typ. peak inrush current $I_{peak}$	1/2 value time, $\Delta t$	Calculated energy, $I_{peak}^2 \Delta t$
28 pcs.	49.3 A	175 $\mu$ s	0.365 A <sup>2</sup> s

### CONVERSION TABLE FOR OTHER TYPES OF MINIATURE CIRCUIT BREAKER

MCB type	Relative quantity of LED drivers
B 10 A	37 %
B 16 A	60 %
B 20 A	75 %
C 10 A	62 %
C 16 A	100 % [see table above]
C 20 A	125 %

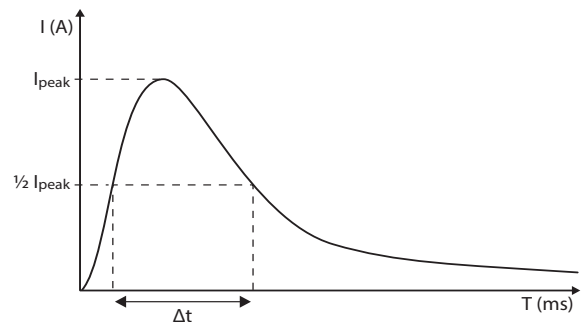

## CONTINUOUS CURRENT

Total continuous current of the drivers and installation environment must always be considered and taken into calculations when installing drivers behind miniature circuit breaker. Example calculation of total drivers amount limited by continuous current:  $n(I_{cont}) = [16 A (I_{nom,TA}) / \text{"nominal mains current with full load"}] \times 0.76$ . This calculation is an example according to recommended precautions due to multiple adjacent circuit breakers (> 9 MCBs) and installation environment ( $T_a$  30 degrees); variables may vary according to the use case. Both inrush current and continuous current calculations are based on ABB S200 series circuit breakers. More specific information in ABB series S200 circuit breaker documentation.

NOTE! Type C MCB's are strongly recommended to use with LED lighting. Please see more details in "MCB information" document in each driver product page in "downloads & links" section.

## Connections and Mechanical Data

Wire size	0.5 mm <sup>2</sup> – 1.5 mm <sup>2</sup>
Wire type	Solid core and fine-stranded
Wire insulation	According to EN 60598
Maximum driver to LED wire length	1.5 m
Weight	246 g
NTC trigger point	8.2 kΩ
IP rating	IP20

## Connections

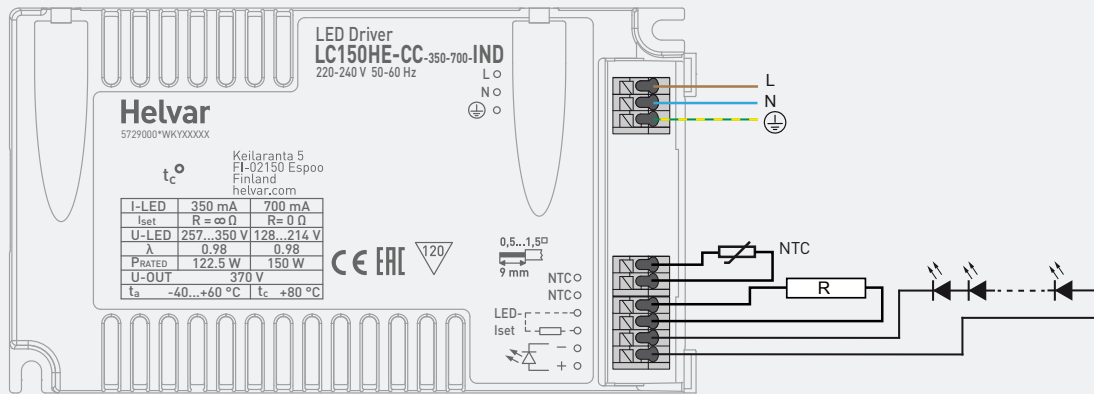

## Dimensions (mm)

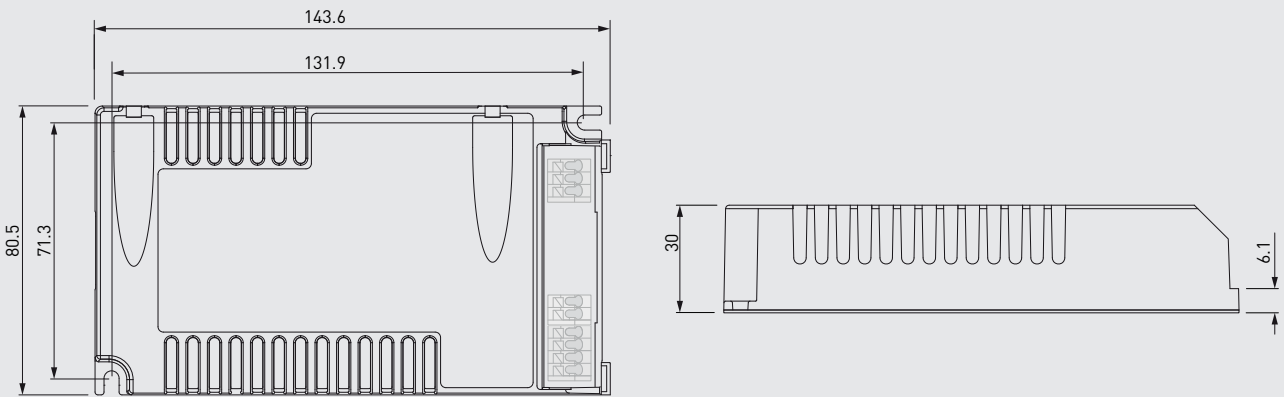

The LED-Iset resistor/current setting values are adjusted according to the LEDset specification. The resistor value for each required output current can thus be calculated from the formula  $R [\Omega] = [5 [V] / I_{out} [A]] * 1000$ . Below are the available LED-Iset resistors from Helvar, pre-adjusted for the most common output currents.

## Helvar LED-Iset resistors and currents (Nominal I<sub>out</sub> (±5 % tol.))

LED-Iset resistor model	MAX	650 mA	600 mA	550 mA	500 mA	475 mA	450 mA	425 mA	400 mA	375 mA	No resistor
I <sub>out</sub> (mA)	700	650	600	550	500	475	450	425	400	375	350
Order code	T90000	T90650	T90600	T90550	T90500	T90475	T90450	T90425	T90400	T90375	N/A
Resistance values (Ω)	0	7.68k	8.25k	9.09k	10k	10.5k	11k	11.8k	12.4k	13.3k	∞

The current can be adjusted also with normal resistors by selecting suitable resistor value (formula  $R [\Omega] = [5 [V] / I_{out} [A]] * 1000$ ). Reference resistor values can be found below order code in the table above.

LC150HE-CC-350-700-IND LED driver is suited for built-in usage in luminaires. With LC1x70-SR, LC-SRB or LC-SRB-LOOP strain reliefs, independent use is possible too (see the strain-relief datasheet for details). In order to have safe and reliable LED driver operation, the LED luminaires will need to comply with the relevant standards and regulations (e.g. IEC/EN 60598-1). The LED luminaire shall be designed to adequately protect the LED driver from dust, moisture and pollution. The luminaire manufacturer is responsible for the correct choice and installation of the LED drivers according to the application and product datasheets. Operating conditions of the LED drivers may never exceed the specifications as per the product datasheet.

## Installation & operation

### Maximum ambient and $t_c$ temperature:

- For built-in components inside luminaires, the  $t_a$  ambient temperature range is a guideline given for the optimum operating environment. However, integrator must always ensure proper thermal management (i.e. mounting base of the driver, air flow etc.) so that the  $t_c$  point temperature does not exceed the  $t_c$  maximum limit in any circumstance.
- Reliable operation and lifetime is only guaranteed if the maximum  $t_c$  point temperature is not exceeded under the conditions of use.

### Current setting resistor

LC150HE-CC-350-700-IND LED driver features a constant current output adjustable via current setting resistor.

- An external resistor can be inserted in to the current setting terminal, allowing the user to adjust the LED driver output current.
- When no external resistor is connected, then the LED drivers will operate at their default lowest current level.
- A standard through-hole resistor can be used for the current setting. To achieve the most accurate output current it is recommended to select a quality low tolerance resistor. Minimum diameter for resistor leg is 0.51mm.
- Always connect the current setting resistor only into the terminals marked with  $I_{set}$  on the LED driver label.
- For the resistor/current value selection, refer to the table on page 3.
- For drivers not providing isolation (non-isolated), current setting resistor must be insulated according safety regulations.

### LED driver earthing

- LC150HE-CC-350-700-IND LED driver is a protective Class I device and designed for Class I luminaires.
- If used inside **Class I** luminaires, this LED driver must always have the protective earth cable connected for safety reasons.
- If used inside **Class II** luminaires, the safety of the luminaire shall be ensured through double/reinforced insulation of live parts. This LED driver is only basic insulated, and provided that luminaire insulation is done according to the latest standards (e.g. IEC/EN 60598-1), the earth terminal of the driver shall be left unconnected. However, the EMC performance of Class I LED drivers change when left unearthed, so it is always the responsibility of the integrator to take measures to ensure that the assembled luminaire complies with latest EMC standards.

### Miniature Circuit Breakers (MCB)

- Type-C MCB's with trip characteristics in according to EN 60898 are recommended.
- Please see more details in "MCB information" document in each driver product page in "downloads & links" section.

## Lamp failure functionality

### No load

When open load is detected, driver limits output voltage according to  $U_{out} (max)$  (abnormal).

### Overload

Driver can withstand overload, however reliable operation is only guaranteed in specified voltage range.

### Underload

Reliable operation of the driver is only guaranteed in specified voltage range.

### Short circuit

Driver can withstand output short circuit.

### Overtemperature

When overtemperature protection is triggered by external NTC thermistor at 8.2 k $\Omega$ , the light output is decreased to 50 % ( $\pm$  5 %) of the nominal.

## Conformity & standards

General and safety requirements	EN 61347-1
Particular safety requirements for DC or AC supplied electronic control gear for LED modules	EN 61347-2-13
Thermal protection class	EN 61347, C5e
Mains current harmonics	EN 61000-3-2
Limits for voltage fluctuations and flicker	EN 61000-3-3
Radio frequency interference	EN 55015
Immunity standard	EN 61547
Performance requirements	EN 62384
Recommended Practices for Modulating Current in High-Brightness LEDs for Mitigating Health Risks to Viewers	IEEE 1789-2015
Compliant with relevant EU directives	
RoHS/REACH compliant	
CE / UKCA marked	

## Label symbols



Thermally controlled control gear, incorporating means of protection against overheating to prevent the case temperature under any conditions of use from exceeding 120 °C.