

## 35 W **Constant Current** LED driver

Product code: 5548  
35 W 220 – 240 VAC 50 – 60 Hz

- High efficiency up to 90%
- Low current ripple, complying with IEEE 1789 standard
- Allows open and flexible luminaire design
- LEDset1 compatible
- Suitable for use in emergency lighting applications
- Suitable for class I and class II luminaires
- Long lifetime, up to 100 000 h
- Driver protection Class II
- For driving Class III (SELV) luminaires, optional strain relief for independent use outside of luminaire (LC-SRA/LC1x30-SR or LC-SRA-LOOP for looping the input cables)

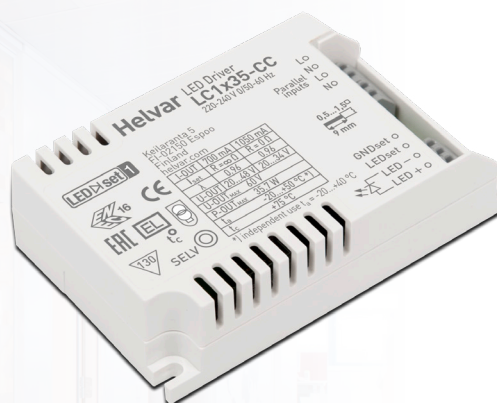

### Functional Description

- Adjustable constant current output: 700 mA (default) to 1050 mA
- Current setting resistor input. Iset resistor values according to LEDset power interface specification
- Adaptive LED overload protection. Reduces output current if overload of 1 - 4 V is detected
- Open and short circuit protection
- Duplicated mains connection terminal. Maximum continuous current via device is 4 A

### Mains Characteristics

Voltage range	198 VAC – 264 VAC
	Withstands max. 320 VAC (max. 1 hour)
DC range	176 VDC - 280 VDC
starting voltage	> 190 VDC
Mains current at full load	0.16 A – 0.19 A
Frequency	0 / 50 Hz – 60 Hz
Power consumption, abnormal load	< 1.5 W
THD at full power	< 15 %
Tested surge protection	1 kV L-N, 2 kV L-GND (IEC 61000-4-5)
Tested fast transient protection	2 kV (IEC 61000-4-4)

### Insulation between circuits

Mains circuit - SELV circuit	Double/reinforced insulation
------------------------------	------------------------------

### Load Output (SELV <60 V)

Output current ( $I_{out}$ )	700 mA (default) – 1050 mA
Accuracy	± 5 %
Ripple	< 2 %*, at ≤ 120 Hz (Low frequency)
	*] Measured according to LEDset power interface specification
PstLM	< 0.03*
SVM	< 0.01*
	*] At full power, measured with Cree XP-G LED modules.
$U_{out}$ (max) (abnormal)	60 V
Starting time	< 400 ms
EOF <sub>I</sub> (EL use)	> 0.98 x output current with AC supply

$I_{out}$	700 mA	1050 mA
$P_{out}$ (max)	33.6 W	35.7 W
$U_{out}$	20 V – 48 V	20 V – 34 V
$\lambda$ , full load	0.96	0.96
Efficiency ( $\eta$ ), full load	90 %	88 %

Operating window

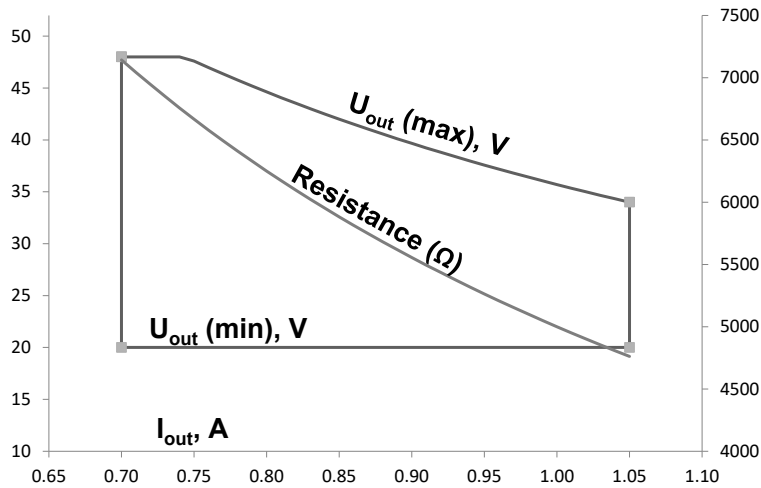

Driver performance

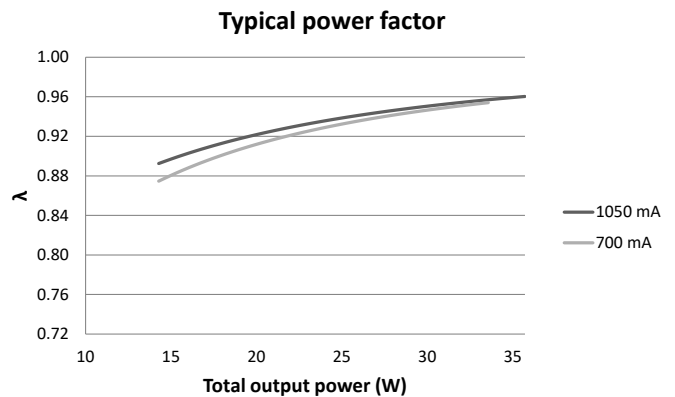
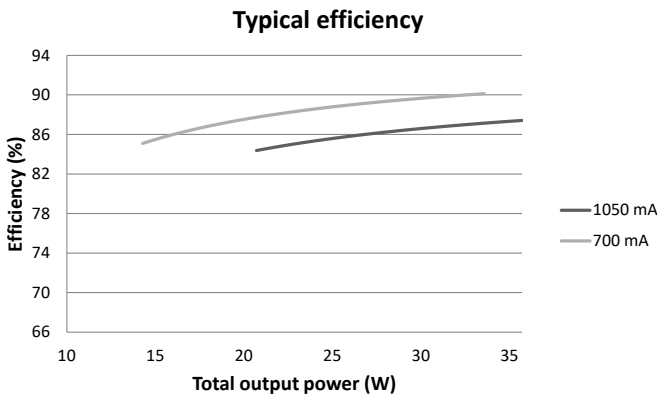

Operating Conditions and Characteristics

Highest allowed $t_c$ point temperature	75 °C
Ambient temperature range in independent use	-20 °C ... +50 °C
Storage temperature range	-20 °C ... +40 °C
Maximum relative humidity	-40 °C ... +80 °C
Life time (90 % survival rate)	no condensation
	100 000 h, at $t_c = 65$ °C
	70 000 h, at $t_c = 70$ °C
	50 000 h, at $t_c = 75$ °C

Quantity of drivers per miniature circuit breaker 16 A Type C

Based on $I_{cont}$	Based on $I_{peak}$	Typ.inrush current	1/2 value time, $\Delta t$	Calculated energy, $I_{peak}^2 \Delta t$
59 pcs.	59 pcs.	6 A	28 $\mu s$	0.00068 A <sup>2</sup> s

CONVERSION TABLE FOR OTHER TYPES OF MINIATURE CIRCUIT BREAKER

MCB type	Relative quantity of LED drivers
B 10 A	37 %
B 16 A	60 %
B 20 A	75 %
C 10 A	62 %
C 16 A	100 % (see table above)
C 20 A	125 %

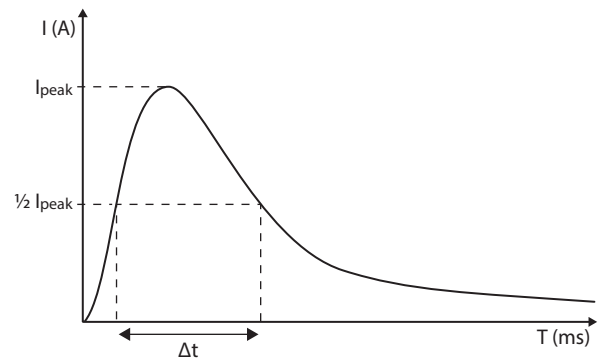

Type C MCB's are strongly recommended to use with LED lighting. Please see more details in "MCB information" document in each driver product page in "downloads & links" section.

## Connections and Mechanical Data

Wire size	0.5 mm <sup>2</sup> – 1.5 mm <sup>2</sup>
Wire type	Solid core and fine-stranded
Wire insulation	According to EN60598
Maximum driver to LED wire length	5 m
Weight	115 g
IP rating	IP20

## Connections

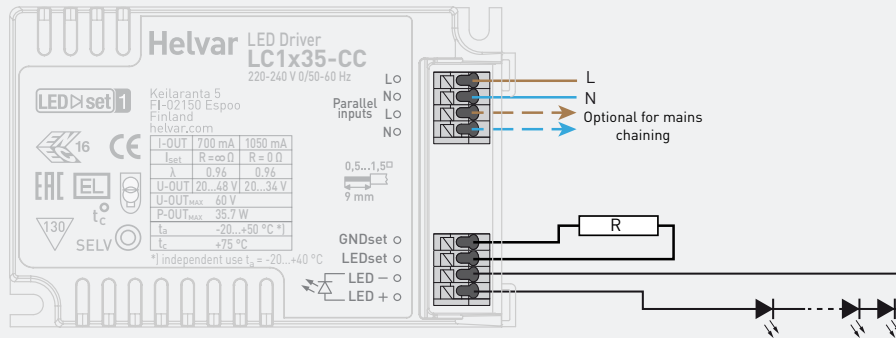

Note:

- Not suitable for load side switching operation.
- Hot plug of LED load is not allowed.

## Dimensions (mm)

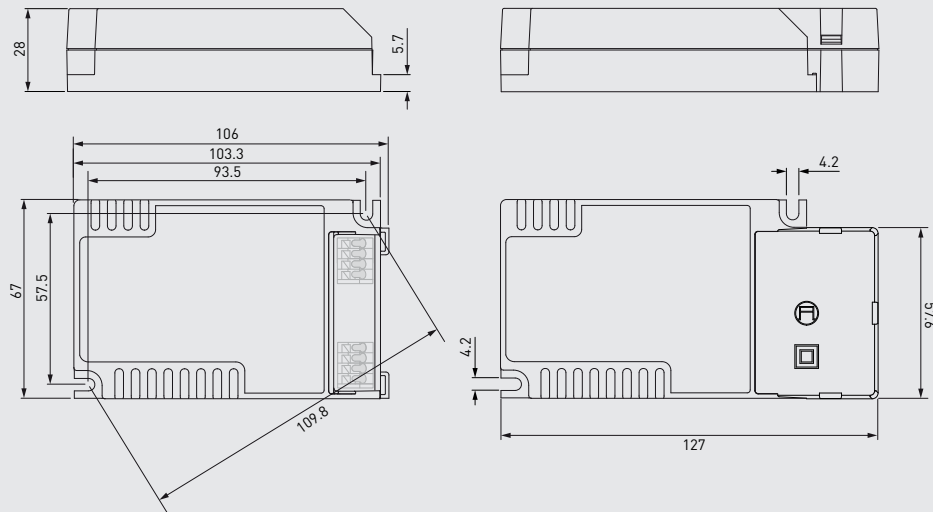

The current setting values are adjusted according to the LEDset specification. The resistor value for each required output current can thus be calculated from the formula  $R [\Omega] = (5 [V] / I_{out} [A]) * 1000$ . Below are the available LED-Iset resistors from Helvar, pre-adjusted for the most common output currents.

### Helvar LED-Iset resistors and currents (Nominal $I_{out} (\pm 5\% \text{ tol.})$ )

LED-Iset resistor model	MAX	1000 mA	950 mA	900 mA	850 mA	800 mA	750 mA	No resistor
$I_{out}$ (mA)	1050	1000	950	900	850	800	750	700
Order code	T90000	T91000	T90950	T90900	T90850	T90800	T90750	N/A
Resistance values ( $\Omega$ )	0	4.99k	5.23k	5.6k	5.90k	6.20k	6.65k	$\infty$

The current can be adjusted also with normal resistors by selecting suitable resistor value (formula  $R [\Omega] = (5 [V] / I_{out} [A]) * 1000$ ). Reference resistor values can be found below order code in the table above.

LC1x35-CC LED driver is suited for built-in luminaire usage. In order to have safe and reliable LED driver operation, the LED luminaires will need to comply with the relevant standards and regulations (e.g. IEC/EN 60598-1). The LED luminaire shall be designed to adequately protect the LED driver from dust, moisture and pollution. The luminaire manufacturer is responsible for the correct choice and installation of the LED drivers according to the application and product datasheets. Operating conditions of the LED drivers may never exceed the specifications as per the product datasheets.

## Installation & operation

### Maximum $t_c$ temperature:

- Reliable operation and lifetime is only guaranteed if the maximum  $t_c$  point temperature is not exceeded under the conditions of use
- Ensure that the  $t_c$  point temperature does not exceed the specified value on the datasheet

### Installation site:

- The general preferred installation position of LED drivers for independent use is to have the top cover facing upwards.

### Current setting resistor

LC1x35-CC LED driver features an adjustable constant current output.

- A standard through-hole resistor can be used for the current setting. To achieve the most accurate output current it is recommended to select a quality low tolerance resistor. Minimum diameter for resistor leg is 0.51mm
- If no external resistor is connected, the LED driver will operate at the lowest current level by default
- Resistor/current values are presented on page 3
- Current setting according to LEDset power interface specification. LED- (cathode side) and GNDset terminals are internally connected together
- Always connect the current setting resistor only between the terminals marked with LEDset and GNDset on the LED driver label.
- More information about operation of the LED driver can be found from LEDset power interface specification

## Conformity & standards

General and safety requirements	EN 61347-1
Particular safety requirements for DC or AC supplied electronic control gear for LED modules	EN 61347-2-13
Additional safety requirements for DC or AC supplied electronic control gear for emergency lighting	EN 61347-2-13 Annex J
Thermal protection class	EN61347, C5e
Mains current harmonics	EN 61000-3-2
Limits for voltage fluctuations and flicker	EN 61000-3-3
Radio frequency interference	EN 55015
Immunity standard	EN 61547
Performance requirements	EN 62384
Recommended Practices for Modulating Current in High-Brightness LEDs for Mitigating Health Risks to Viewers	IEEE 1789-2015
Compliant with relevant EU directives	
ENEC and CE / UKCA marked	

## Label symbols



Thermally controlled control gear, incorporating means of protection against overheating to prevent the case temperature under any conditions of use from exceeding 130 °C.



AC/DC supplied electronic control gear for emergency lighting purposes intended for connection to a centralized emergency power supply.



This LED driver follows the LEDset power interface specification.

Company Address:

**Helvar Oy Ab**

Keilaranta 5

FI-02150, Espoo