

5609 ActiveAhead Node Advanced

ActiveAhead Node Advanced is a member of the truly intelligent wireless lighting control solution Helvar ActiveAhead®. It connects standard DALI devices to the ActiveAhead Bluetooth® mesh network. It offers addressed local DALI control line which allows individually set light output levels for the connected DALI luminaires.

The connected ActiveAhead nodes share information, such as movement detections, through the mesh network, and a mobile app allows you to adjust the parameters of the system.

The ActiveAhead Node Advanced is very easy to install even with thick mains cables and is equipped with integrated spacious strain reliefs. Each Node Advanced has a DALI output with dual parallel connectors.



Both ActiveAhead sensors as well Helvar DALI-2 system sensors can be connected to anticipate the most suitable lighting conditions right before they are needed. Thanks to its smart software algorithm, Helvar ActiveAhead is able to learn how the space is used to predict the luminaire operation accordingly.

Learning is based on the data that the node receives from locally connected sensors and from other ActiveAhead nodes in the network. Since it never stops learning, the ActiveAhead Node Advanced will adapt to any future changes in its environment, such as a wall installation or removal.

Key Features

- Connects DALI devices into the wireless Helvar ActiveAhead network
- Offers local addressed DALI control line
- Customisation via mobile app
- Quick and simple installation with mains power and inbuilt DALI power supply unit

Installation Diagram

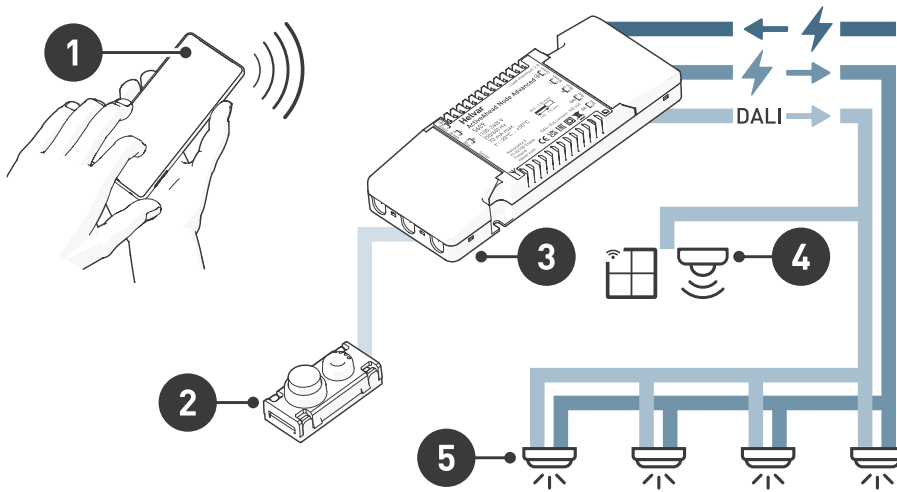

1. ActiveAhead Mobile App
2. ActiveAhead Sense
3. ActiveAhead Node Advanced
4. DALI-2 sensors and DALI-2 panels
5. DALI Luminaires

Connections

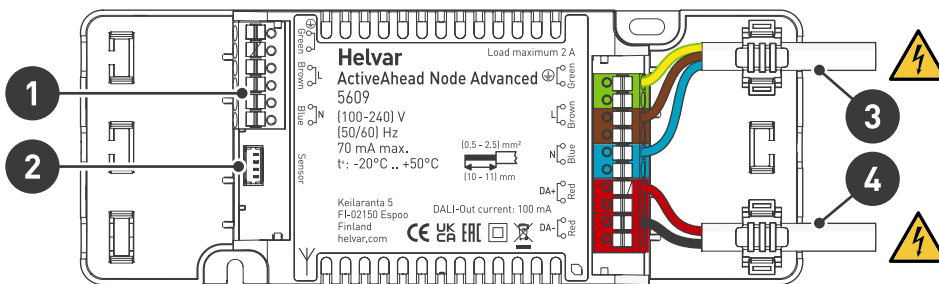

1. Alternative mains supply
2. Sensor connection
3. Preferred mains supply (max. 2 A*)
4. DALI connectors

* = 2 A fuse between alternative mains supply (1.) and preferred mains supply (3.)

⚠ Warning: FELV terminals marked "Risk of electric shock" are not safe to touch!

Note: The wire cover has been removed from the unit for this illustration.

Note: Do not cover! Leave a minimum clearance of 50 mm.

An independent controlgear that can be used where normally flammable materials, including building insulation, are or may be present, but cannot be abutted against any material and cannot be covered in normal use.

Dimensions (mm)

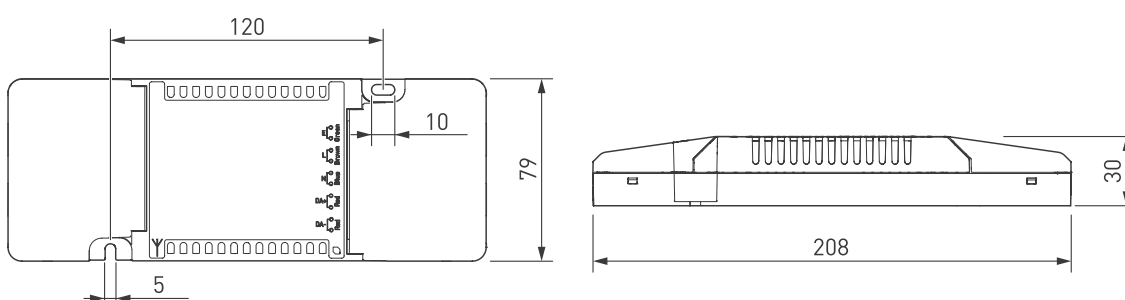

Technical Data

Supported DALI device types

- DT0 Fluorescent lamp control gear
- DT1 Self-contained emergency control gear
- DT4 Incandescent lamp dimmer
- DT5 Analog-to-digital converter Conversion to DC (0/1-10 V)
- DT6 LED lamp control gear
- DT7 Switching (relay) control gear
- DT8 Colour control gear (colour temperature Tc only)
- Part 301 Push buttons
- Part 303 Occupancy sensors
- Part 304 Light sensors
- Helvar DIGIDIM system sensors: 320, 321, 322, 341 and 342

Note: Supported device types depend on the software version of the Node Advanced.

Connections

Doubled terminals for extending the mains and DALI cables

Mains:	3 × 2-pole push-fit terminals Wire section: 0.5–2.5 mm ² , solid or stranded.
DALI:	2 × 2-pole push-fit terminals Wire section: 0.5–2.5 mm ² , solid or stranded.

Electrical data

Mains supply:	100–240 VAC, 50/60 Hz, Max. 70 mA
Mains output:	Max. 2 A
Output pulse withstand (inrush) capability:	Max. 8 pcs load devices
Note: 2 A fuse between alternative mains supply and preferred mains supply.	
Input power:	Max. 5 W
Output current for DALI:	Typical 100 mA (Max. 250 mA)
Sensor interface:	3.3 V
Isolation mains to DALI:	Basic isolation (250 V)

Isolation mains to sensor:	Reinforced isolation (250 V)
Isolation DALI to sensor:	Supplementary isolation (250 V)

Wireless connectivity

Frequency:	2.4 GHz
Transmission power:	0 dBm
Technology:	Bluetooth® Mesh
Antenna pattern:	Omnidirectional
Max. distance between Nodes:	15 m in free space

Note: To ensure proper operation the mesh network must consist of a minimum 10 ActiveAhead Nodes.

Operating and storage conditions

Number of connected DALI devices:	Max. 16 DALI control gear and DIGIDIM addresses Max. 8 DALI-2 input device addresses In total, max. 100 mA current consumption
--	--

Note: The total number of connected devices is limited by the addresses and the DALI current consumption limitation.

Note: There must be only one ActiveAhead Node on one DALI line.

Max. DALI cable length:	300 m
Operating temperature:	0 °C to +40 °C
Relative humidity:	Max. 85 %, noncondensing
Storage temperature:	-20 °C to +70 °C

Mechanical data

Dimensions:	208 x 79 x 30 mm
Material (casing):	PC-FR
Colour:	White (RAL 9016)
Weight:	182 g
Safety class:	For independent use

Conformity and standards

Conformity:	
EMC emission / immunity:	EN 55015 / EN 61547
Safety:	EN 61347-2-11
RED:	EN 300 328, EN 301 489-1, EN 301 489-17
Environment:	Complies with WEEE and RoHS directives.